

SONY HVR-M15AU - PROFESSIONAL VIDEO CASSETTE RECORDER/PLAYER OPERATING INSTRUCTIONS MANUAL



Quick Links

[Rear Panel](#)

Table of Contents

Table of Contents

Front Panel

menu button

play button

Rear Panel

Supplied Remote Commander

Preparing the Power Supply

Inserting/Ejecting Cassettes

Notes on Playback/Recording

Installing the Unit Vertically

Major Differences among HDV1080i, DVCAM, and DV Formats

Input/Output Signals in EE Mode

Recording Input Signals and Recording Formats

Playback Tape Format and Output Signals

Settings for Output Signals from Each Jack

Connections for Playback

Settings for Playback

Playback Procedures

Playback Functions

playing at various speeds

Auto Repeat

Connections for Recording

Settings for Recording

Recording Procedures

Recording Functions

Connections for Dubbing

Dubbing Procedures

Connecting the Unit to a Computer

Preparations

Menu Structure

Menu Contents

display set menu

audio set menu

[others menu](#)

[power sources](#)

[alarm messages](#)

[Notes on the Videocassette Recorder](#)

[Cleaning of the Video Heads](#)

[Notes on the Video Cassettes](#)

[About Moisture Condensation](#)

[Digital Hours Meter](#)

[About the Built-in Rechargeable Battery](#)

[Using your Videocassette Recorder abroad](#)

[Notes on the License](#)

[Other ManualsLib Projects](#)

Digital HD Videocassette Recorder

Operating Instructions

Before operating the unit, please read this manual thoroughly,
and retain it for future reference.

HDV
HDV 1080i **DVCAM**[™] **DV** Digital Video Cassette **Mini DV** Digital Video Cassette **PROGRESSIVE**

**HVR-M15AU/M15AN/M15AE/
M15AP**

Table of Contents

Chapter 1 Overview

| | |
|---|-----------|
| Features | 4 |
| Location and Function of Parts | 6 |
| Front Panel | 6 |
| Rear Panel | 12 |
| Supplied Remote Commander | 16 |
| Displaying Various Data | 18 |

Chapter 2 Playback and Recording

| | |
|---|-----------|
| Notes on Power Supply and Video Cassettes | 20 |
| Preparing the Power Supply | 21 |
| Inserting/Ejecting Cassettes | 21 |
| Notes on Playback/Recording | 22 |
| Installing the Unit Vertically..... | 23 |
| Recording Format and Input/Output Signals | 24 |
| Major Differences among HDV1080i, DVCAM, and DV Formats | 24 |
| Input/Output Signals in EE Mode | 25 |
| Recording Input Signals and Recording Formats | 26 |
| Playback Tape Format and Output Signals..... | 26 |
| Settings for Output Signals from Each Jack | 27 |
| Playback | 29 |
| Connections for Playback | 29 |
| Settings for Playback | 31 |
| Playback Procedures | 31 |
| Playback Functions | 32 |
| Auto Repeat..... | 35 |
| Using the Unit as a Videocassette Recorder | 36 |
| Connections for Recording | 36 |
| Settings for Recording | 38 |
| Recording Procedures | 40 |
| Recording Functions | 40 |

Chapter 3 Dubbing/Editing

| | |
|--|-----------|
| Dubbing to Other Equipment | 41 |
| Connections for Dubbing | 41 |
| Dubbing Procedures | 44 |
| Editing (Connecting a Computer) | 45 |
| Connecting the Unit to a Computer | 45 |
| Preparations..... | 46 |

Chapter 4 Adjusting and Setting Through Menus

| | |
|------------------------------|-----------|
| Operating Menus | 48 |
| Menu Structure..... | 49 |
| Menu Contents | 50 |

Chapter 5 Maintenance

| | |
|---|-----------|
| Troubleshooting | 59 |
| Warning Indicators and Messages..... | 65 |
| Notes on Use..... | 67 |
| Notes on the Videocassette Recorder..... | 67 |
| Cleaning of the Video Heads | 67 |
| Notes on the Video Cassettes..... | 68 |
| About Moisture Condensation | 69 |
| Digital Hours Meter | 70 |
| About the Built-in Rechargeable Battery..... | 70 |
| Using your Videocassette Recorder abroad..... | 70 |
| Notes on the License | 70 |

Appendix

| | |
|------------------------------|-----------|
| Notes on Dubbing..... | 71 |
| About i.LINK..... | 74 |
| Specifications | 75 |
| Index | 78 |
| Submenu Index..... | 80 |

Overview

Features

The HVR-M15AU/M15AN/M15AE/M15AP is a digital HD videocassette recorder supporting the HDV and DVCAM/DV formats. The unit produces stable, superior picture quality using digital processing and by separating image signals into color difference signals and a luminance signal (component video).

The main features of the unit are described below.

HDV/DVCAM/DV format

The unit can perform HDV/DVCAM/DV recording and playback on a DVCAM format or DV format video cassette.

- **HDV format:** The unit can perform HDV (High-Definition Digital Video) recording and playback. The compression system of the HDV format is the MPEG2 system adopted in high-definition broadcasting and the Blu-ray Disc System. The unit adopts the 1080 scanning lines (interlaced 1080/60i, 1080/50i, progressive 1080/24p, 1080/30p and 1080/25p) format of the HDV specifications. The recording bit rate is approximately 25 Mbps. The unit is equipped with i.LINK digital interfaces, and can be digitally connected with televisions or computers which are compatible with the interfaces.
- **DVCAM/DV format:** DVCAM is based on the consumer DV format, which uses the 4:1:1 component digital format (60i) or the 4:2:0 format (50i), and provides a 1/4-inch digital recording format for professional use. The unit provides both DVCAM format recording/playback and DV format in SP mode recording/playback.

For details, see “Major Differences among HDV1080i, DVCAM, and DV Formats” on page 24.

Compatible with both interlaced and progressive HDV recording/playback

The unit can record or play back HDV 1080/60i, 1080/24p, 1080/30p, 1080/50i and 1080/25p videos.

Also, the unit can play back HDV 720/30p, 720/24p and 720/25p videos.

(For recording, signals can be input only via an i.LINK digital interface.)

Here for the unit, 60i indicates field frequency 59.94 Hz. 24p and 30p indicate frame frequency 23.98 Hz and 29.97 Hz, respectively.

High definition down convert function

When you want to play back a tape recorded in HDV format, you can down convert images to output them. This function allows you to preview recorded-images on a monitor which is not compatible with the High-Definition (HD) format. Also, you can select an aspect ratio from SQUEEZE, LETTER BOX (except , HDV/DV jack output), or EDGE CROP.

Multiple input/output interfaces

The following jacks are provided with the unit and enable connection with various devices:

- **Input jacks:** S VIDEO IN jack, VIDEO IN jack and AUDIO IN jacks
- **Output jacks:** COMPONENT OUT jacks, S VIDEO OUT jack, VIDEO OUT jack and AUDIO OUT jacks
- **Input-output jack:** i HDV/DV jack

JOG AUDIO function

If you use the optional DSRM-10 remote control unit (not supplied), audio can be monitored at various playback speeds in jog/shuttle mode. (Jog audio cannot be output when the tape is recorded in HDV format.)

Screen Language Setting

You can select the language to be used for screen displays.

The default language setting is English.

See “LANGUAGE” in the “OTHERS” menu on page 57 for details on how to change the screen language.

Compact size allowing vertical installation

The compact size of the unit allows installation in a vertical position and saves space. During non-linear editing, you can install the unit in a vertical position next to the computer and save working space.

Easy maintenance functions

- **Self-diagnostics/alarm functions:**

The system automatically detects an invalid operation, bad connection, or a malfunction, and outputs a description, a cause, and a recovery method to the COMPONENT OUT jacks, S VIDEO OUT jack and VIDEO OUT jack.

- **Digital hours meter:**

A digital hours meter counts four types of time data—operating time, drum rotation time, tape running time, and tape threading/unthreading. The digital hours data is indicated on the menu.

DVCPRO, **DV**, and **MiniDV** are trademarks of Sony Corporation.

HDV is a trademark of Sony Corporation and Victor Company of Japan, Ltd.

All other product names mentioned here may be the trademarks or registered trademarks of their respective companies. “TM” and “®” are not mentioned in every case in this manual.

Location and Function of Parts

Front Panel

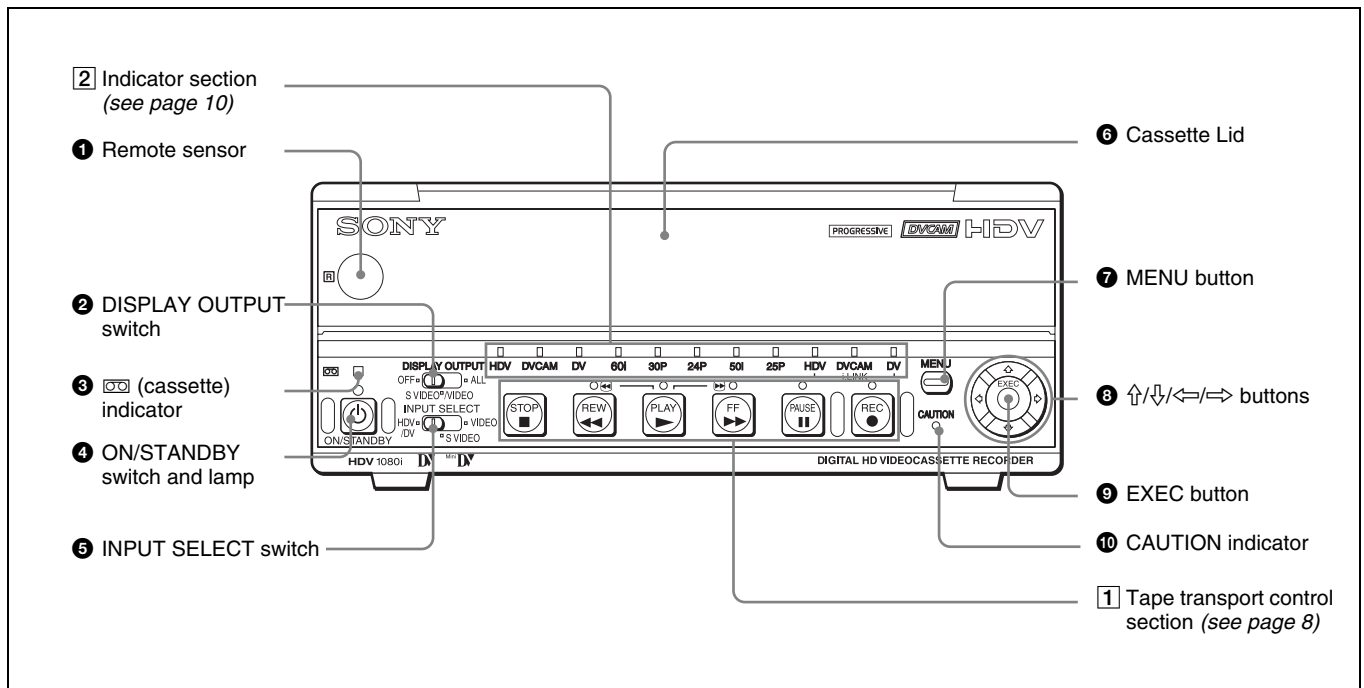

1 Remote sensor

Note

In addition to the Remote Commander supplied with the unit, the unit accepts signals from any Sony Remote Commander whose command mode is set to VTR4. To disable control from a Remote Commander, set [COMMANDER] in the [OTHERS] menu to [CONTROL S].

2 DISPLAY OUTPUT switch

Selects the destination for the text data to be superimposed via output jacks.

OFF: Does not output text data to superimpose.

S VIDEO/VIDEO:

Superimposes text data to S VIDEO OUT jack and VIDEO OUT jack.

ALL: Superimposes text data to COMPONENT OUT jacks, S VIDEO OUT jack and VIDEO OUT jack.

For details on text data, see "Displaying Various Data" on page 18.

3 (cassette) indicator

Lights when a digital video cassette is loaded.

Does not light up when there is no cassette loaded in the unit.

This indicator blinks while a cassette is being ejected.

For details, see "Inserting/Ejecting Cassettes" on page 21.

4 ON/STANDBY switch and lamp

Press this switch to turn the unit on, and the ON/STANDBY lamp lights up in green. When you press this switch again, the unit goes into the standby mode and the lamp lights up in red.

5 INPUT SELECT switch



Use this button to select the signal input jack from the **i** HDV/DV jack, S VIDEO IN jack, and VIDEO IN jack.

HDV/DV: Inputs a signal from the **i** HDV/DV jack.

S VIDEO: Inputs a signal from the S VIDEO IN jack.

VIDEO: Inputs a signal from the VIDEO IN jack.

Notes

- Do not change the setting of this switch while recording is in progress, or it will cause noise to be added to images and sounds. Also, the part of the tape where the change of setting is applied will not be recorded properly. Also, the time code may be recorded discontinuously.
- If you change the setting of this switch while recording is in progress, the output signal via the  HDV/DV jack may be interrupted. Also, the unit may detect signals, such as a copyright information signal, incorrectly.
- When a signal is input via the  HDV/DV jack, the settings of the menu listed below are unavailable.
 - 60i/50i SEL
 - AUDIO MODE
 - AUDIO LOCK
 - AUDIO AGC
 - AUDIO REC LV

6 Cassette Lid

Open this lid to insert or eject a cassette.

For details on cassettes that can be used, see “Notes on Power Supply and Video Cassettes” on page 20.

For details of inserting or ejecting a cassette, see “Inserting/Ejecting Cassettes” on page 21.

7 MENU button

Press this button to display the menu list on screen.

For details on the menus, see “Operating Menus” on page 48.

8  buttons

Use these buttons in making menu settings and other settings.

9 EXEC (execute) button

Use this button in menu settings.

10 CAUTION indicator

Blinks when an error occurs.

For details on cautions, see “Self-diagnosis display/Warning Indicators” on page 65.

1 Tape transport control section

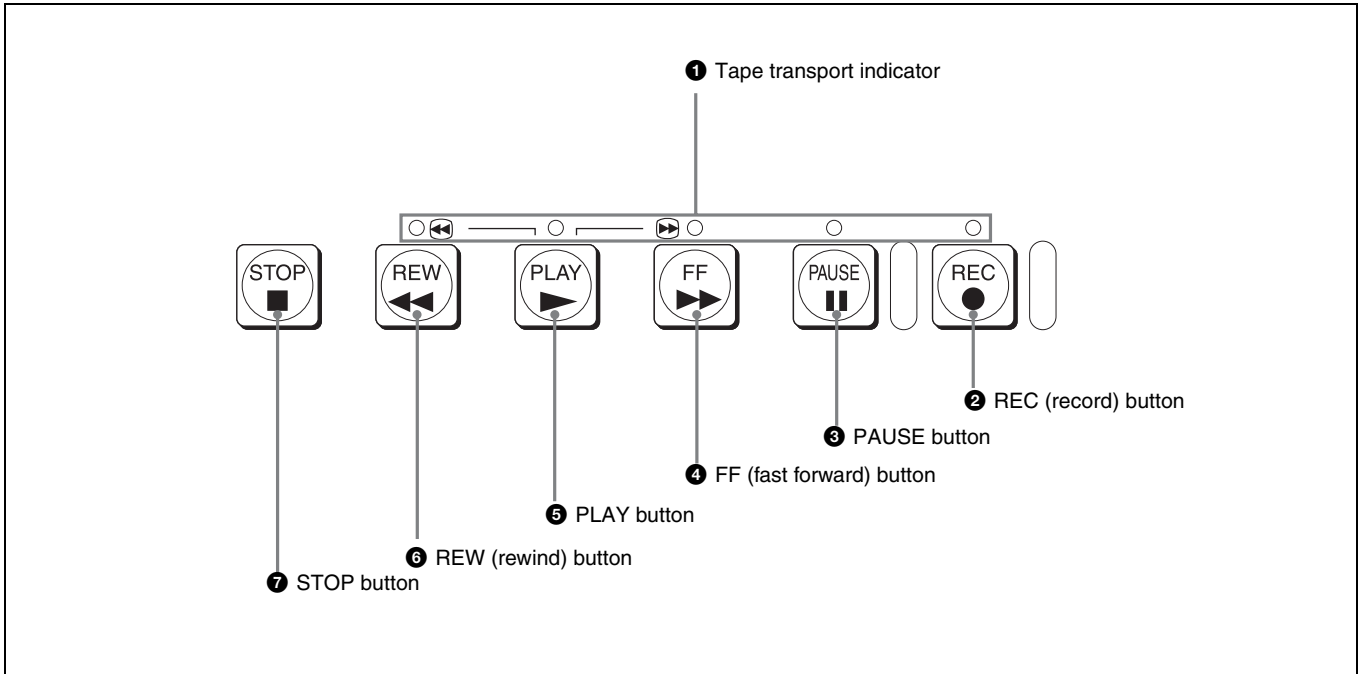

1 Tape transport indicator

2 REC (record) button

When you press and hold this button, then press the PLAY button, each indicator lights and recording starts. If you press this button while the tape is stopped, you can check EE picture and audio signals for a short time. When the  HDV/DV jack is selected, if [HDV/DV IN TC] in the [TC/UB SET] menu is set to [EXTERNAL], you can also check the EE time code signals. Press the STOP button to end the check.

For details, see “EE/PB SEL” in the “IN/OUT REC” menu on page 52.

For details on time codes, see “TC/UB SET” on page 56.

Notes

- The unit does not have an LP recording mode for the consumer DV format. Only SP recording mode is available.
- To set the unit to recording pause mode with the DSRM-10 remote control unit (not supplied), press the PAUSE button while holding down the PLAY button to set the unit to the playback pause mode, then press the REC button on the DSRM-10.

- When the recording mode is set to HDV format, it may take a few seconds to start recording. During this time, the REC indicator blinks.

3 PAUSE button

Press this button to set the unit to pause mode. The indicator lights during recording or playing. Press this button again to resume the operation.

4 FF (fast forward) button

When you press this button, the indicator lights and the tape is fast forwarded. During fast forward, the picture does not appear on the monitor. (You can see the picture as it is seen in EE mode¹⁾ during fast forward.) To locate a scene while monitoring the picture, press and hold this button during fast forward, playback or in the playback pause mode (picture search).

Notes

- If you set [EE/PB SEL] in the [IN/OUT REC] menu to [PB], EE picture and EE audio signals are not output (page 52).

1) “EE” stands for “Electric to Electric.” In EE mode, the video and audio signals input to the VCR’s recording circuitry do not pass through any magnetic conversion circuits but are output via electric circuits only. This mode is used to check the input signals and adjust input levels. The pictures output in EE mode are referred to as EE pictures.

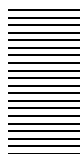

- If you set [FF/REW SPEED] in the [VTR SET] menu to [SHUTTLEMAX], the picture is played back during fast forward.

For details on running speed with [SHUTTLEMAX], see “FF/REW SPEED” in “VTR SET menu” on page 55.

5 PLAY button

When you press this button, the indicator lights and playback begins.

If you press this button while holding down the REW button during stop, the tape is rewound to its beginning and starts playing automatically (during rewind, the REW indicator lights and the PLAY indicator blinks).

Notes

- When the unit is playing back a part of the tape where the recording format has been changed to HDV format, DVCAM format, or DV format, or between 60i system (including 24p and 30p) and 50i system (including 25p), the picture and sound may be distorted.
- The unit cannot play back a tape recorded in the LP recording mode of the consumer DV format.

6 REW (rewind) button

When you press this button, the indicator lights and the tape starts rewinding. During rewind, the picture does not appear on the monitor. (You can see the picture as it is seen in EE mode during rewind.) To locate a scene while monitoring the picture, hold this button down during rewind, playback or in the playback pause mode. If you press the PLAY button while holding down this button during stop, the tape is rewound to its beginning and starts playing automatically. (During rewind, the REW indicator lights and the PLAY indicator blinks.)

Notes

- If you set [EE/PB SEL] in the [IN/OUT REC] menu to [PB], EE picture and EE audio signals are not output (page 52).
- If you set [FF/REW SPEED] in the [VTR SET] menu to [SHUTTLEMAX], the picture is played back during rewind.

For details on running speed with [SHUTTLEMAX], see “FF/REW SPEED” in “VTR SET menu” on page 55.

7 STOP button

Press this button to stop the tape transport operation completely.

Note

If you set [EE/PB SEL] in the [IN/OUT REC] menu to [PB], EE picture and EE audio signals are not output during stop (page 52).

2 Indicator section

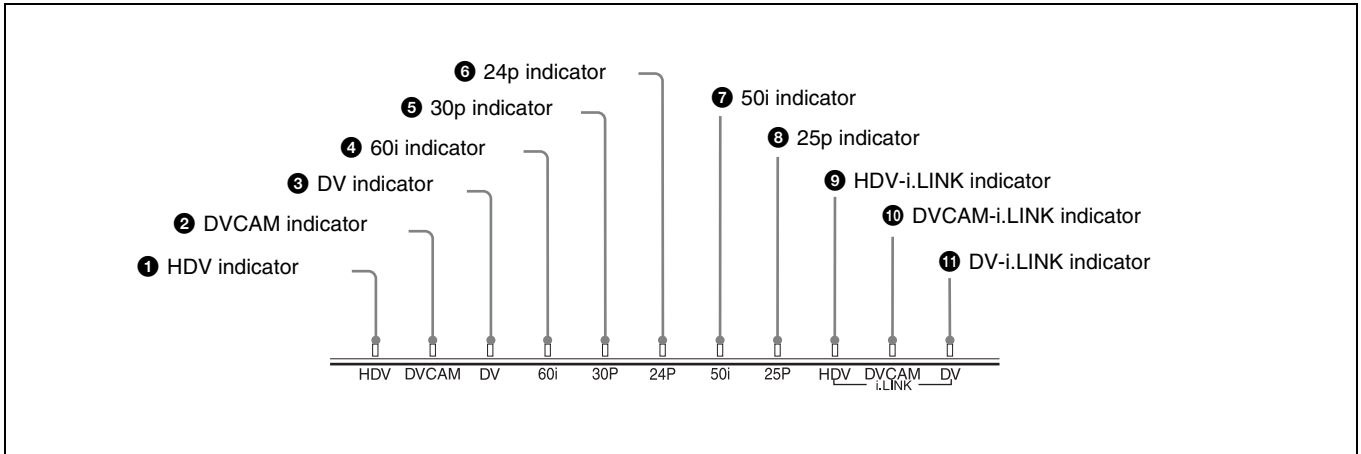

1 HDV indicator

Lights when the unit is in either of the following operating states.

- When a tape recorded in HDV format is being played back.
- When [HDV/DV SEL] in the [IN/OUT REC] menu is set to [AUTO] and HDV signals are being input from the **i** HDV/DV jack.
- When [HDV/DV SEL] in the [IN/OUT REC] menu is set to [HDV].

2 DVCAM indicator

Lights when the unit is in either of the following operating states.

- When a tape recorded in DVCAM format is being played back.
- When the following four conditions are met:
 - When [HDV/DV SEL] in the [IN/OUT REC] menu is set to [AUTO].
 - When [**☑** REC MODE] in the [IN/OUT REC] menu is set to [DVCAM].
 - When DV or DVCAM signals are being input from any of the input jacks.
 - During recording or in EE mode.
- When the following three conditions are met:
 - When [HDV/DV SEL] in the [IN/OUT REC] menu is set to [DV].
 - When [**☑** REC MODE] in the [IN/OUT REC] menu is set to [DVCAM].
 - During recording or in EE mode.

3 DV indicator

Lights when the unit is in either of the following operating states.

- When a tape recorded in DV format (SP mode only) is being played back.
- When the following four conditions are met:
 - When [HDV/DV SEL] in the [IN/OUT REC] menu is set to [AUTO].
 - When [**☑** REC MODE] in the [IN/OUT REC] menu is set to [DV].
 - When DV or DVCAM signals are being input from any of the input jacks.
 - During recording or in EE mode.
- When the following three conditions are met:
 - When [HDV/DV SEL] in the [IN/OUT REC] menu is set to [DV].
 - When [**☑** REC MODE] in the [IN/OUT REC] menu is set to [DV].
 - During recording or in EE mode.

4 60i indicator

Lights when the unit is in one of the following operating states.

- During recording or in EE mode when [60i/50i SEL] in the [OTHERS] menu is set to [60i].
- When 1080/60i signals or NTSC signals are input from the **i** HDV/DV jack.
- When a tape that has 1080/60i signals or NTSC signals is being played back.

5 30p indicator

Lights when the unit is in either of the following operating states.

- When a tape recorded in 1080/30p format or 720/30p format is being played back.
- When 1080/30p signals are input from the **i** HDV/DV jack.

6 24p indicator

Lights when the unit is in either of the following operating states.

- When a tape recorded in 1080/24p format or 720/24p format is being played back.
- When 1080/24p signals are input from the **i** HDV/DV jack.

7 50i indicator

Lights when the unit is in one of the following operating states.

- During recording or in EE mode when [60i/50i SEL] in the [OTHERS] menu is set to [50i].
- When 1080/50i signals, or PAL signals are input from the **i** HDV/DV jack.
- When a tape that has 1080/50i signals or PAL signals is being played back.

8 25p indicator

Lights when the unit is in either of the following operating states.

- When a tape recorded in 1080/25p format or 720/25p format is being played back.
- When 1080/25p signals are input from the **i** HDV/DV jack.

9 HDV-i.LINK indicator

Lights when HDV signals are input/output through the i.LINK interface.

10 DVCAM-i.LINK indicator

Lights when DVCAM signals are input/output through the i.LINK interface.

11 DV-i.LINK indicator

Lights when DV signals are input/output through the i.LINK interface.

Rear Panel

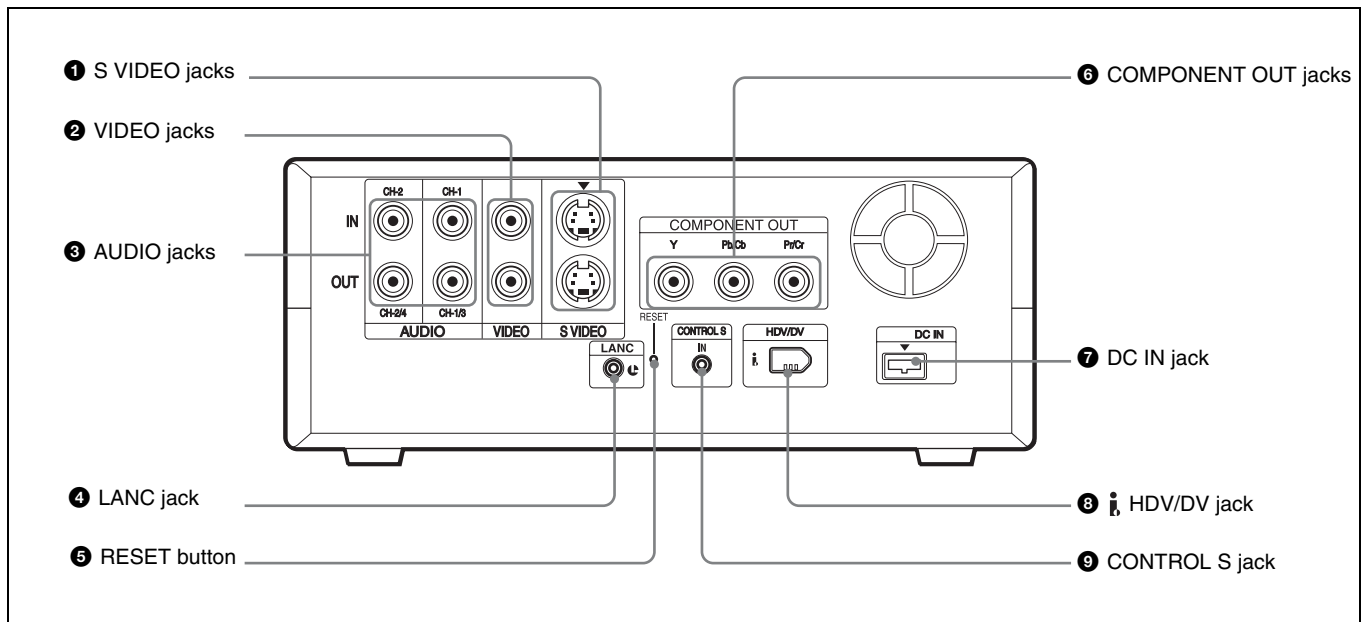

1 S VIDEO jacks

To connect a device equipped with S video jacks, use the S VIDEO jacks on the unit.

If you use the S VIDEO jacks, you can input/output high-quality video with less signal quality deterioration than if connected to the standard VIDEO jack.

When the DISPLAY OUTPUT switch on the front panel is set to S VIDEO/VIDEO or ALL, text data such as the time code, menus, and alarm messages are superimposed on an external monitor connected to the S VIDEO OUT jack (page 18).

For details on the output of the S VIDEO jacks, see “Notes on all video output jacks” on page 14.

2 VIDEO jacks

Use these jacks to input and output analog video signals. Text data is superimposed on a monitor in the same way as with an S VIDEO jack connection (page 18).

For details on the output of the VIDEO jacks, see “Notes on all video output jacks” on page 14.

3 AUDIO jacks

Use these jacks to input and output analog audio signals. When [AUDIO MODE] in the [AUDIO SET] menu is set to [FS32K], sounds will be recorded on channels 1 and 2.

Notes

- When the audio mode is 32 kHz (4-channel), you can set [AUDIO MIX] in the [AUDIO SET] menu to select the audio signals to be output (page 54). When you select [MIX], the audio output level becomes 50% (–6 dB) of the original audio levels on each channel.
- If you input a sound at a level that exceeds the acceptable range, the recorded sound is distorted. For details on the available volume levels, see “Specifications” on page 75.

4 LANC jack

Use this jack when controlling the tape transport operation of the unit using a device that has a LANC¹⁾ jack.

Notes

- The LANC jack on the unit has only LANC-S functions. The unit has no LANC-M functions. A device that is set to LANC-S mode cannot be connected to the unit. Either the unit or the other device may not operate properly.
- When using the unit as a player, set LANC mode on the recorder to M. A VCR that does not have an M/S switching function cannot be used to operate the unit.

1) LANC (Local Application Control bus system): Bidirectional interface used to control a consumer VCR

- When the device to be connected to the unit has a LANC-M function to switch between SHUTTLE A/B, select SHUTTLE A for an HDV-formatted tape, and SHUTTLE B for a DVCAM/DV (SP)-formatted tape.
- A LANC connection transmits command signals for playback, stop, pause playback, as well as the time code, tape counter, and data status of the unit.
- Jacks labeled CONTROL L have the same function as LANC jacks.
- There are some limitations when you edit an HDV-formatted tape.
Refer to the “Notes” in “Editing (Connecting a Computer)” on page 45.

5 RESET button

If you press this button with the tip of a ballpoint pen or similar tool, the following settings are initialized.

- [CLOCK SET] (*page 58*) and [60i/50i SEL] (*page 58*) in the [OTHERS] menu.
- The settings on the unit other than the menu settings.

6 COMPONENT OUT jacks

Use these jacks to output component signals.

To connect a device equipped component video input connectors, use the COMPONENT OUT jacks on the unit. If you use the COMPONENT OUT jacks, you can output high-quality video with less signal quality deterioration than if you use the S VIDEO jacks.

You can set the output video format by using [COMPONENT] of [VIDEO OUT] in the [IN/OUT REC] menu.

When the DISPLAY OUTPUT switch is set to ALL, text data such as time code, menu, and alarm messages are superimposed on a monitor connected using the COMPONENT OUT jacks (*page 18*).

Notes

- When you change the video format setting of [COMPONENT] of [VIDEO OUT] in the [IN/OUT REC] menu, the video signal output from the S VIDEO OUT jack, VIDEO OUT jack, or  HDV/DV jack may be distorted for a moment.
- When you play back a tape in DVCAM/DV format and while an EE picture in NTSC/PAL is displayed, either the 480i resolution or the 576i resolution is output, regardless of the setting of [COMPONENT] of [VIDEO OUT] in the [IN/OUT REC] menu.

- When [COMPONENT] of [VIDEO OUT] in the [IN/OUT REC] menu is set to either [1080i/480i] or [1080i/576i], 1080/24p and 1080/30p video signals are converted to 1080/60i and 1080/25p video signals are to 1080/50i, and output.

- When you play back an HDV-formatted tape with copyright protected signals or input HDV signals with copyright protection to the  HDV/DV jack, pictures may be output in either 480i (NTSC) or 576i (PAL) format, regardless of the setting of [COMPONENT] of [VIDEO OUT] in the [IN/OUT REC] menu.

- The output level of the COMPONENT OUT jacks is as follows:

Output at 480i (NTSC)

With [BETACAM] selected in [480i LEVEL] of the [IN/OUT REC] menu

Y: 1.0 Vp-p

(with 0.286 Vp-p sync negative, output impedance 75 Ω (ohms), unbalanced)

Pb/Cb/B-Y, Pr/Cr/R-Y: 0.7 Vp-p

(output impedance 75 Ω (ohms), unbalanced)
(75% color bars with 7.5 IRE setup)

With [SMPTE] selected in [480i LEVEL] of the [IN/OUT REC] menu

Y: 1.0 Vp-p

(with 0.3 Vp-p sync negative, output impedance 75 Ω (ohms), unbalanced)

Pb/Cb/B-Y, Pr/Cr/R-Y: 0.7 Vp-p

(output impedance 75 Ω (ohms), unbalanced)
(100% color bars with no setup)

Output with other settings

Y: 1.0 Vp-p

(output impedance 75 Ω (ohms), unbalanced)

Pb/Cb/B-Y, Pr/Cr/R-Y: 0.7 Vp-p

(output impedance 75 Ω (ohms), unbalanced)
(100% color bars with no setup)

480i/480p:

Y: with 0.3 Vp-p sync negative

1080i/720p:

Y/Pb/Pr: with 0.6 Vp-p 3-level sync

7 DC IN jack

Connect to the AC outlet using the supplied AC Adaptor.

(Continued)

8 i HDV/DV jack (6-pin)

Use this jack to input/output digital signals that comply with the i.LINK standard. Use this jack when a device connected to the unit has an i.LINK jack. If you connect the unit and another device using the i HDV/DV jack, you can minimize deterioration of picture quality during recording, dubbing, or capturing still pictures, all by means of digital signals processing.

For details, refer to the instruction manual of the external device.

Notes

- When you connect a computer and the unit with an i.LINK cable, check the direction of the jack. If you forcibly insert the jack, the terminal may be damaged or cause the unit to malfunction.
- This jack is only compatible with HDV (1080i)/DVCAM/DV signals.
For details, see "About i.LINK" on page 74.
- If the unit is connected to a device equipped with an i.LINK jack, when you intend to disconnect or reconnect the i.LINK cable, turn off the device and pull out the plug of its power cord from the AC outlet beforehand. If you connect or disconnect the i.LINK cable while the device is connected to the AC outlet, high-voltage current (8 to 40 V) is output from the i.LINK jack of the device to the unit. This may cause a malfunction.
- Even though the i HDV/DV jack of the unit is a 6-pin type, no power is supplied.
For details on each setting when HDV/DV signals are input, see "HDV/DV SEL" (page 50).
- When you change the video format setting of [COMPONENT] in [VIDEO OUT] of the [IN/OUT REC] menu, the video signal output from the S VIDEO OUT jack, the VIDEO OUT jack, or the i HDV/DV jack may be distorted.
For details on the output of the i HDV/DV jack, see "Notes on all video output jacks" (page 14).

9 CONTROL S jack

Connect this jack to a DSRM-10 remote control unit (not supplied) to operate the unit. You can also use a DSRM-20 (no longer manufactured; not supplied).

Note

When you use a CONTROL S device, set [COMMANDER] in the [OTHERS] menu to [CONTROL S].

Notes on all video output jacks

- When you change the video format setting of [COMPONENT] of [VIDEO OUT] in the [IN/OUT REC] menu, the video signals output from S VIDEO OUT jack, VIDEO OUT jack, or i HDV/DV jack may be distorted.
- The unit is only compatible with standard video signals. If you input the types of video signals shown below, recorded picture and sound may be distorted.
 - Signals from some home game machines
 - Blue background screen or gray background screen images from a consumer VCR
 - Pictures played at a speed other than normal by a VCR that does not have TBC (Time Base Corrector)
 - Video signals in which the sync signals are distorted
 - Signals from a defective cassette (tape or recording condition is bad) played by an analog VCR that does not have TBC
- When DVCAM/DV signals which are input from the i HDV/DV jack, or video signals which are from the VIDEO IN jacks or S VIDEO IN jacks, are output to each analog output jack, the distortion of the video signals occurs at the bottom of the TV monitor display due to the jitter. Depending on the display area of the TV monitor you have, the distortion of the picture may appear at the bottom of the screen. This is not a malfunction. Pictures may be distorted or not be displayed depending on the TV monitors. This will not appear while recording with the unit. Be aware of these phenomena when you connect other recording device via the analog jacks of the unit.
- Depending on the TV monitor being connected, the screen may blink or be distorted when DVCAM/DV signals which are input from the i HDV/DV jack, or video signals which are from the VIDEO IN jacks or S VIDEO IN jacks, are output to the VIDEO OUT jacks. Be aware of these phenomena when you connect other recording device to these jacks. This will not appear while recording with the unit.
- During recording or in EE mode, the subcarrier of the color signal to be output from the unit is not synchronized with the horizontal sync signal. The color of the picture or the horizontal position of the picture may be distorted depending on the type of monitor connected to the unit.

-
- To output video signals to the VIDEO, S VIDEO, or COMPONENT OUT jacks without text data, set the DISPLAY OUTPUT switch to OFF, or press the DATA CODE or SEARCH SELECT button on the remote commander.



Supplied Remote Commander

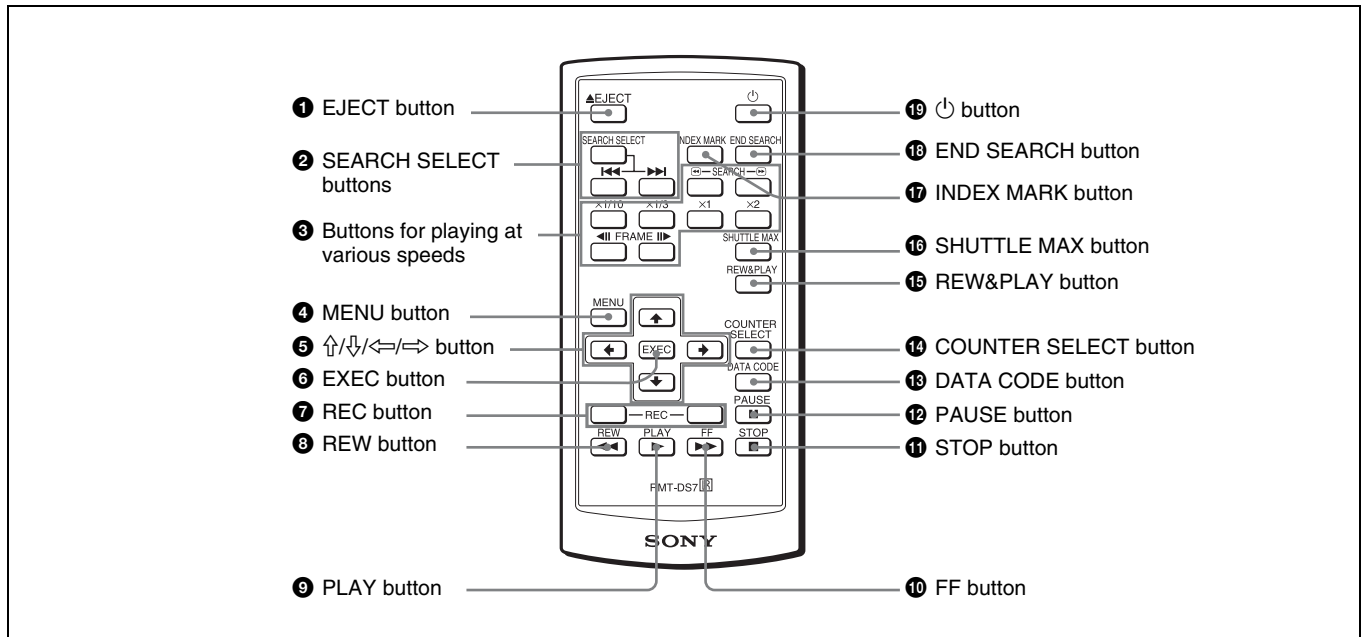

1 **EJECT button**

2 **SEARCH SELECT buttons**

Press these buttons to search for scenes using the search function.

For details on the search function, see “Searching using the search function” on page 34.

3 **Buttons for playing at various speeds**

You can play back a tape at normal speed or at a speed other than normal with these buttons.

For details, see “Playing at various speeds” on page 33.

4 **MENU button**

Press this button to display the menu on the screen.

For details on the menu, see “Operating Menus” on page 48.

5 **button**

Press these buttons to operate the cursor on the menu screen or to move the display position of the counter.

6 **EXEC (execute) button**

Press this button to input the value set on various menu setting screens.

7 **REC (record) buttons**

When you press both these buttons at the same time, the REC indicator and the PLAY indicator on the front panel light and recording begins.

8 **REW (rewind) button**

9 **PLAY button**

10 **FF (fast forward) button**

11 **STOP button**

12 **PAUSE button**

13 **DATA CODE button**

Press this button to display the data codes (recording date/time).

For details on data codes, see “Displaying information (data codes) recorded on a tape” on page 32.

14 **COUNTER SELECT button**

This button is not available for the unit.

15 **REW&PLAY (rewind and play) button**

Press this button to rewind the tape to its beginning and start playing automatically. (During rewind, the REW indicator lights and the PLAY indicator blinks on the unit.)

16 **SHUTTLE MAX button**

During tape playback, press this button to play back the video at the maximum speed.

17 INDEX MARK button

Press this button during recording to mark an index.
For details on indexes, see “Marking an index” on page 40.

18 END SEARCH button

Press this button to play back the end of the last recorded part for only 5 seconds and stop automatically. Once you eject the video cassette, this function does not operate.

19 ⏻ (on/standby) button**Notes**

- The command mode of the supplied Remote Commander is set to VTR4. You cannot change the command mode setting.
- Set [COMMANDER] in the [OTHERS] menu to [WIRELESS] to enable the Remote Commander to control the unit (page 57).
- In addition to the Remote Commander supplied with the unit, the unit accepts signals from any Sony Remote Commander with a command mode set to VTR4.

To disable control from Remote Commander, set [COMMANDER] in the [OTHERS] menu to [CONTROL S].

Before using Remote Commander

Remove the insulation sheet before using the Remote Commander.

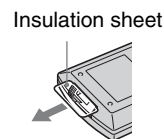
**To change the battery of the Remote Commander**

- 1 While pressing on the tab, inset your fingernail into the slit to pull out the battery case.
- 2 Place a new battery with the + side facing up.
- 3 Insert the battery case back into the Remote Commander until it clicks.

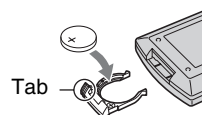
**Note on batteries**

When the lithium battery becomes weak, the operating distance of the Remote Commander may shorten, or the Remote Commander may not function properly. In this case, replace the battery with a Sony CR2025 lithium battery. Use of another battery may present a risk of fire or explosion.

WARNING

Battery may explode or leak if mistreated. Do not recharge, disassemble or dispose of in fire.

Caution

Replace the battery with the specified type only. Otherwise, fire or injury may result.

Displaying Various Data

The unit can display various superimposed text data on the built-in LCD monitor, and also on an external monitor connected to the unit. When external monitors are connected to the unit, you can select the destination of the text data to be displayed using the DISPLAY OUTPUT switch.

In this operation manual, the menu screen, etc., is displayed in English. You can change the desired language with the screen language setting. For details, see “LANGUAGE” in the “OTHERS” menu on page 57.

Menu screen

Press the MENU button to display the menu screen. For details on the menus, see “Chapter 4 Adjusting and Setting Through Menus” on page 48.

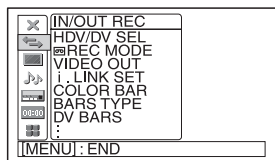

Data display screen

You can confirm important information for normal recording or playback, such as time code or remaining tape time, on the screen. You cannot specify the items of information to be displayed.

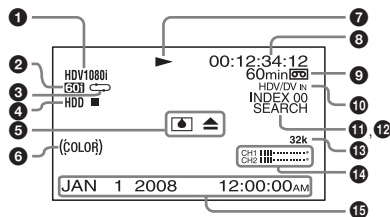

- 1 Format indicator**
[HDV1080i], [HDV720p], [DVCAM], or [DV SP] are displayed.
- 2 60i/24p/30p/50i/25p indicator**
- 3 Repeat indicator**
Displays the repeat indicator when [AUTO REPEAT] in the [VTR SET] menu is set to [ON] (page 55).

4 HVR-DR60/HVR-MRC1 connection indicator
[HDD] is displayed while an HVR-DR60 is connected using the HDV/DV jack. When an HVR-MRC1 is connected, [CF] is displayed.

5 Alarm indicator
Displays an alarm indicator. For details on alarm indicators, see “Warning Indicators and Messages” on page 65.

6 x.v.Color indicator
Displays an x.v.Color indicator while pictures recorded in x.v.Color are played back. For details on x.v.Color, see “Playback with x.v.Color output” on page 23.

7 Tape transport mode indicator
Displays the tape transport mode.

8 Time code indicator
In the drop frame mode, a period is displayed between the minutes and seconds (i.e., 00:12.58:00).

Note

When you playback a tape without a time code or with a time code recorded in different formats, the time code cannot be displayed correctly.

9 Remaining tape time indicator
Displays the remaining tape time. For details, see “ REMAINING” in the “DISPLAY SET” menu on page 53.

Notes

- The remaining tape time displayed is an estimated time.
- When you insert a cassette of which the tape has been rewound to the beginning, this indicator does not show the remaining tape time. The remaining tape time is displayed after the tape runs for a while.

10 INPUT SELECT indicator
Changes according to the position of the INPUT SELECT switch. ([HDV/DV IN], [S VIDEO IN] or [VIDEO IN])

11 (Index) indicator
Displays when an index has been marked.

12 Search indicator

Displays the search mode when you search for scenes using the Remote Commander.

For details on the search function, see “Searching using the search function” on page 34.

13 Audio mode indicator

In the recording mode, displays 32k when you select [FS32K] for [AUDIO MODE] in the [AUDIO SET] menu.

When you select [FS48K], 48k is displayed.

During playback, displays the audio mode recorded on the tape. During i.LINK input, displays the audio mode of the signal input to the  HDV/DV jack.

Notes

- The audio mode will not be displayed when [HDV/DV SEL] in the [IN/OUT REC] menu is set to [HDV].
- Signals other than HDV/DVCAM lock mode will become non-standard audio and NS32k/NS48k is displayed during playback or when the signal is input from the  HDV/DV jack.

14 Audio level meters

For details of the audio level meter display, see [AUDIO MIX] in the [AUDIO SET] menu (page 54).

Note

If the audio level meter turns red in EE or recording mode, the sound will be distorted because the input level is too high. (However, when the audio mode is set to 32 kHz (4-channel, 12 bits) and [AUDIO MIX] (page 54) is set to [MIX], the audio level meter does not turn red regardless of the input level.) During playback or while HDV/DV signals are input, the level meter does not turn red.

15 Date/time indicator

When you press the DATA CODE button of the Remote Commander or set [DATA CODE] in the [DISPLAY SET] menu to [DATE], you can display the recording date/time.

For details on the date/time indicator, see “Displaying information (data codes) recorded on a tape” on page 32.

Playback and Recording

Notes on Power Supply and Video Cassettes

Usable cassettes

For recording in the HDV/DV format, we recommend you use a DigitalMaster™ cassette such as standard HDV/DVCAM/DV cassette (PHDV-276DM, etc.), or mini HDV/DVCAM/DV cassette (PHDVM-63DM, etc.).

For recording in the DVCAM format, we recommend you use a standard DVCAM cassette, Mini-DVCAM cassette, or DigitalMaster™ shown above.

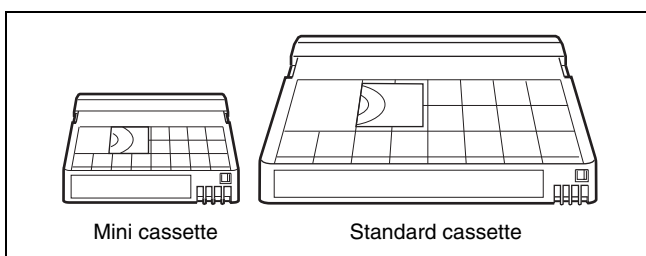

Cassette compatibility

A DV format cassette tape can be used for HDV. The recording bit rate and recording track pitch on a tape of the HDV1080i system used for the HVR-M15AU/M15AN/M15AE/M15AP are about 25 Mbps and 10 μ m, respectively. The specifications are the same as those of home use DV (SP) tapes. The recording time on an HDV tape is also the same as that of a DV (SP) tape. The track pitch of DVCAM is 15 μ m, which is 1.5 times that of HDV/DV (SP). Therefore, the recording time

using DVCAM recording on the same tape will be two-thirds of the time available when HDV/DV (SP) recording is used.

Cassette memory

Some mini cassettes and standard cassettes have the cassette memory (CIII mark). The unit, however, does not support the cassette memory function.

However, if you use the DSR-25/45/50 as a recorder, the unit accesses cassette memory only if the recorder is set to [AUTO  CIII].

To save a recording

To prevent accidental erasure of a recording, set the REC/SAVE switch on the cassette to SAVE. To record on a tape, set the switch to REC.

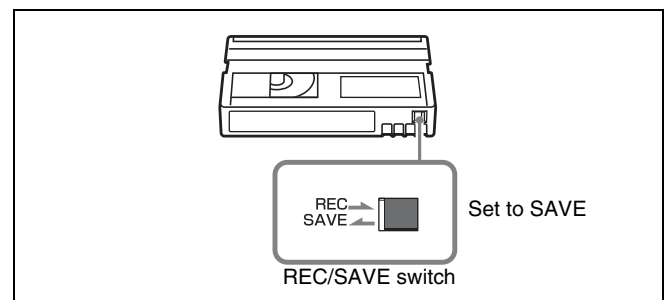

Checking the tape for slack

Using a paper clip or a similar object, turn the reel gently in the direction shown by the arrow. If the reel does not move, there is no slack.

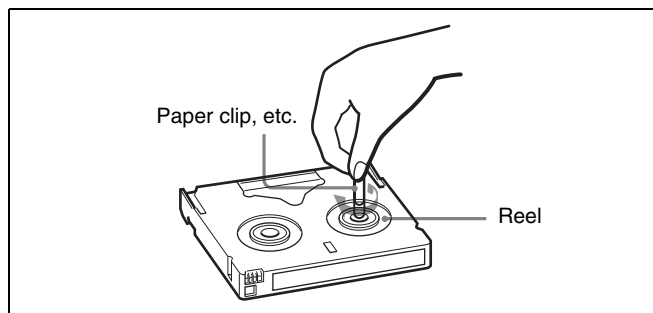

Preparing the Power Supply

Connect the power cord (supplied) to the AC Adaptor (supplied) and the DC plug of the AC Adaptor to DC IN jack on the unit. Then, connect the power plug to the wall outlet. When you disconnect the power code from the wall outlet, be sure to unplug the power plug from the wall outlet first.

PRECAUTION

Even if this unit is turned off, AC power (house current) is still supplied to it while connected to the wall outlet via the AC Adaptor.

Notes

- Never short-circuit the DC plug of the AC Adaptor with a metal object. A short circuit can damage the unit.
- Use a nearby wall outlet when using the AC Adaptor. Disconnect the AC Adaptor from the wall outlet immediately if any malfunction occurs.
- Do not use the AC Adaptor placed in a narrow space, such as between a wall and furniture.

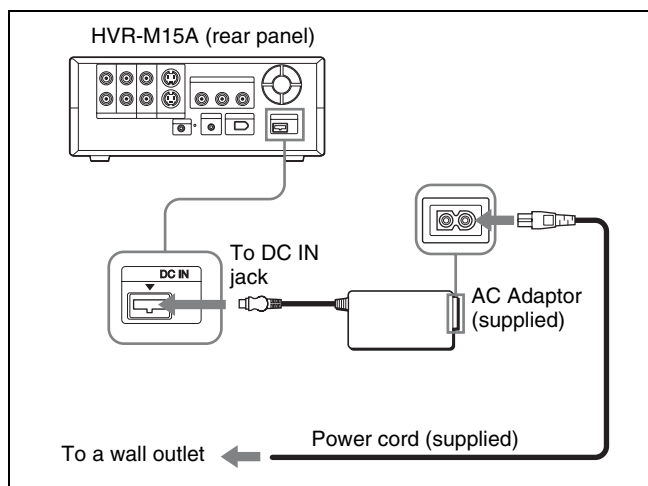

The [CLOCK SET] screen appears when you turn on the unit for the first time.

For details on [CLOCK SET], see page 58.

Inserting/Ejecting Cassettes

To insert a cassette

Notes

- Do not insert the cassette forcibly. The unit may be damaged.
- Do not eject/load the cassette in a place subject to light. Close the cassette lid when the unit is in use. The internal sensor of the unit may operate incorrectly if too much light falls on the unit.

- 1 With the unit powered on, confirm that  indicator is off, and then open the cassette lid.

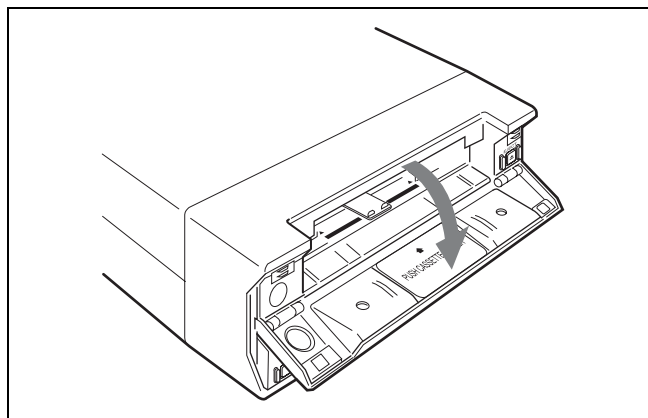

(Continued)

Notes on Power Supply and Video Cassettes

- 2 After checking the tape for slack, hold the cassette so that the tape window is facing upward, then insert it into the unit. The tape is inserted into the unit automatically.

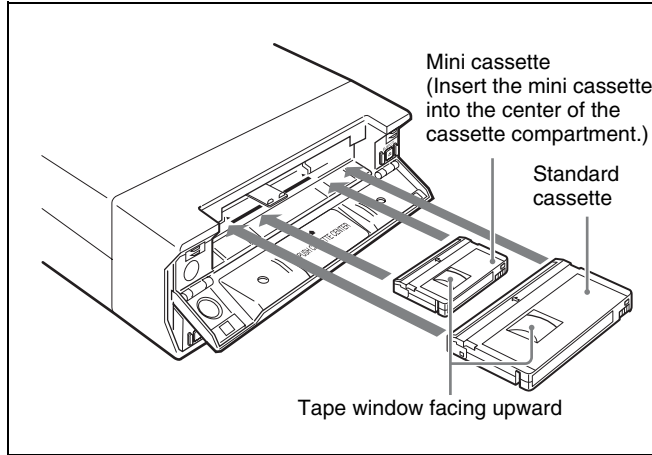

Notes

- When inserting a cassette, hold the back edge of the cassette in the center and push it until the cassette is inserted deep into the unit. If you hold the ends, the cassette may not be loaded properly.
- If the cassette does not load or is loaded only halfway, eject it once, then insert it again. In such a case, if you insert the cassette forcibly, the cassette may not be loaded properly or malfunctions may occur.
- It takes a few seconds for the unit to recognize the cassette and find the proper location on the tape being loaded.

- 3 Close the cassette lid.

To eject the cassette

- 1 With the unit powered on, open the cassette lid. Press the EJECT button located at the right side of the cassette compartment.

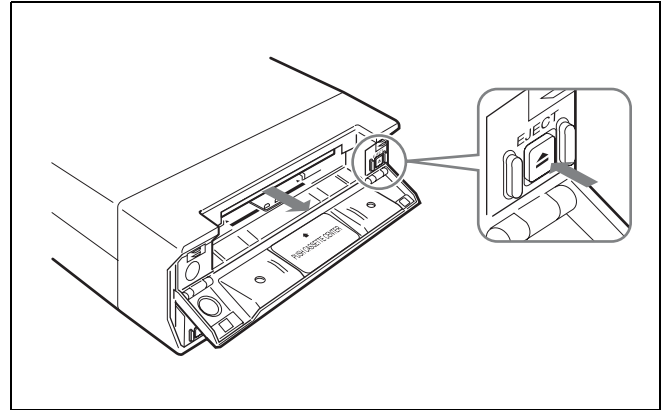

The cassette is disengaged and ejected.

- 2 Remove the cassette from the unit and close the cassette lid.

Notes on Playback/Recording

No compensation for contents of the recording
Contents of the recording cannot be compensated for if recording or playback is not successful due to a malfunction of the unit, video tape, etc.

Copyright precautions

Television programs, films, video tapes, and other materials may be copyrighted. Unauthorized recording of such materials may be contrary to the copyright laws.

Copyright signal

On playback

When the cassette you play back on the unit contains copyright signals, you cannot copy it to a tape in another device connected to your unit.

On recording

You cannot record software on the unit that contains copyright control signals for copyright protection of software.

[Cannot record due to copyright protection.] appears on the screen of the external monitor if you try to record such software. The unit does not record copyright control signals on the tape when it records.

Limitations caused by differences in format

The unit can record and play back tapes recorded in HDV format (1080/60i, 1080/24p, 1080/30p, 1080/50i and 1080/25p), DVCAM format, or DV format (SP mode).

The unit can input/output and record signals via the  HDV/DV jack.

The unit can play back pictures recorded in 720/24p, 720/25p or 720/30p of the HDV format, but you cannot input/output these pictures via the  HDV/DV jack.

The unit cannot input/output, record, or play back a tape recorded in 720/60p or 720/50p of the HDV format, and 480p/576p of the SD format.

For details, see “Major Differences among HDV1080i, DVCAM, and DV Formats” on page 24.

Notes

The unit can play back pictures recorded in 720/24p, 720/25p or 720/30p of the HDV format, but the formats of the output pictures have limitations. For details, see page 27.

If a tape contains portions recorded in two or more different formats, the following limitations are applied when you play back the tape with the unit:

- The image may be distorted and noise may occur at the point where the recording format changes on the tape.
- The tape transport control buttons may be disabled until the tape speed is stabilized.

Note on playback on other equipment

A tape recorded in HDV format with the unit cannot be played back with devices not compatible with the same format. We recommend confirming the contents of the tape by playing back the tape with the unit before playing it back on another video equipment.

Playback with x.v.Color output

The unit can play back pictures recorded in x.v.Color.

- x.v.Color is a brand name that Sony is proposing as a easy-to-remember name for the xvYCC standard.
- The xvYCC standard is an international standard for color space within moving images. The xvYCC standard can reproduce a wider range of colors than the standards used for current broadcasting.

Installing the Unit Vertically

Put the unit into the supplied rack as illustrated below. You can install it either standing on its left side or on its right side.

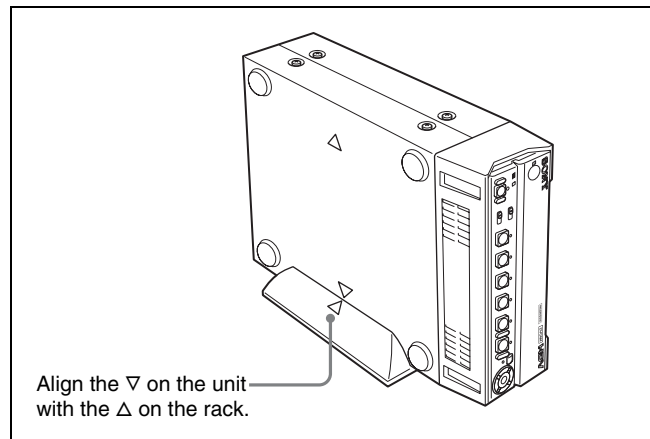

Notes

- Be sure to use the supplied rack. Without the rack, the unit may topple over and may be damaged or may cause injury.
- Install the unit on a flat place.
- When inserting a cassette, hold the unit until it is loaded into the unit. Otherwise the cassette may fall out and the tape may be damaged.

For details on inserting a cassette, see “Inserting/Ejecting Cassettes” on page 21.

- The name plate is located on the left side of the unit. You may not see it when using the supplied rack.

Recording Format and Input/Output Signals

Major Differences among HDV1080i, DVCAM, and DV Formats

(This unit and other equipment for professional use may be functionally extended. For details, see the notes below the table.)

| Specification | HDV1080i ¹⁾ | DVCAM | DV (SP) |
|------------------------------------|---|---|--|
| Track pitch | 10 μ m | 15 μ m | 10 μ m |
| Audio sampling frequency | 16 bit: 48 kHz | 12 bit: 32 kHz 16 bit: 48 kHz | 12 bit: 32 kHz 16 bit: 32 kHz, 44.1 kHz, 48 kHz ³⁾ |
| Audio recording mode ²⁾ | Lock mode | Lock mode | Unlock mode ⁴⁾ |
| Time code | Drop frame mode (60i/24p/30p only) ⁵⁾ No user bits ⁶⁾ | NTSC: SMPTE time code (DF/NDF, including user bits) ⁶⁾ PAL: EBU time code (including user bits) ⁶⁾ | Drop frame mode (NTSC only) ⁵⁾ No user bits ⁶⁾ |

- 1) The unit cannot record 4-channel sound in HDV format.
- 2) There are two modes for audio signal recording: Lock mode and Unlock mode. In Lock mode, the sampling frequencies of audio and video are synchronized. In Unlock mode, adopted by the consumer DV format, the two sampling frequencies are independent. Lock mode maintains high compatibility with higher formats and offers better digital processing and smoother transition than Unlock mode when you edit audio.
- 3) The unit cannot record in DV format with 16 bit: 32 kHz or 44.1 kHz.
- 4) The unit has been functionally extended with a function for switching between Lock mode and Unlock mode.
- 5) The unit has been functionally extended with a function to enable selecting DF/NDF for 60i (including 24p and 30p) with HDV or DV (SP) format.
- 6) The unit is not equipped with user bit setting function.

Input/Output Signals in EE Mode

Select the signal input with the INPUT SELECT switch on the front panel (page 6).

○: Output, —: No output or N/A

| Input signal | Input jack | | Output jack | | | | |
|----------------|---------------|----------|----------------------|---|-----------------|--------------------|------------------------|
| | | | HDV/DV | | COMPONENT OUT | VIDEO/S VIDEO | |
| | | | Output signal format | | | | |
| | Input format | DVCAM/DV | HDV | | | | |
| Digital signal | HDV/DV | HDV | 1080/60i | — | — | ○ ¹⁾ | ○ (480i) ²⁾ |
| | | | 1080/24p | — | — | ○ ¹⁾ | ○ (480i) ²⁾ |
| | | | 1080/30p | — | — | ○ ¹⁾ | ○ (480i) ²⁾ |
| | | | 1080/50i | — | — | ○ ¹⁾ | ○ (576i) ²⁾ |
| | | | 1080/25p | — | — | ○ ¹⁾ | ○ (576i) ²⁾ |
| | | | 720/30p/25p/24p | — | — | — | — |
| | | DVCAM/DV | — | — | ○ ³⁾ | ○ ³⁾ | |
| Analog signal | VIDEO/S VIDEO | | ○ | — | ○ ³⁾ | ○ ^{3) 4)} | |

1) The format of the picture output from the HDMI OUT jack and COMPONENT OUT jacks can be set in [COMPONENT] of [VIDEO OUT] in the [IN/OUT REC] menu (page 51). For details, see the settings for down conversion (page 27).

2) The signals are down converted and output.

The format of the picture output from the VIDEO OUT jack and the S VIDEO OUT jack can be selected from [SQUEEZE], [LETTER BOX] and [EDGE CROP] in [DOWN CONVERT] of [VIDEO OUT] in the [IN/OUT REC] menu (page 51).

3) When DVCAM/DV signals which are input from the HDV/DV jack, or video signals which are from the VIDEO IN jacks or S VIDEO IN jacks, are output to each analog output jack, the distortion of the video signals occurs at the bottom of the TV monitor display due to the jitter. Depending on the display area of the TV monitor you have, the distortion of the picture may appear at the bottom of the screen. This is not a malfunction.

Pictures may be distorted or not be displayed depending on the TV monitors. This will not appear while recording with the unit.

Be aware of these phenomena when you connect other recording device via the analog jacks of the unit.

4) Depending on the TV monitor being connected, the screen may blink or be distorted when DVCAM/DV signals which are input from the HDV/DV jack, or video signals which are from the VIDEO IN jacks or S VIDEO IN jacks, are output to the VIDEO OUT jacks.

Be aware of these phenomena when you connect other recording device to these jacks. This will not appear while recording with the unit.

Notes

- HDV 720/30p/25p/24p signals can be played back, but cannot be input/output via the HDV/DV jack on the unit.
- HDV 720/60p, HDV720/50p and SD 480p/576p signals cannot be input/output, recorded, or played back on the unit.

Recording Format and Input/Output Signals

Recording Input Signals and Recording Formats

Select the signal input with the INPUT SELECT switch on the front panel (page 6).

○: Recordable, —: Not recordable

| Input signal | Input jack | | Recording format | | | |
|----------------|---------------|-----------------|------------------|-------|---------|--------------|
| | | | HDV | DVCAM | DV (SP) | |
| | | | | | | Input format |
| Digital signal | i HDV/DV | HDV | 1080/60i | ○ | — | — |
| | | | 1080/24p | ○ | — | — |
| | | | 1080/30p | ○ | — | — |
| | | | 1080/50i | ○ | — | — |
| | | | 1080/25p | ○ | — | — |
| | | 720/30p/25p/24p | — | — | — | |
| | | DVCAM/DV | — | ○ | ○ | |
| Analog signal | VIDEO/S VIDEO | | — | ○ | ○ | |

Notes

- HDV 720/30p/25p/24p signals can be played back, but cannot be input/output via the i HDV/DV jack on the unit.
- HDV 720/60p, HDV 720/50p and SD 480p/576p signals cannot be input/output, recorded, or played back on the unit.

Playback Tape Format and Output Signals

○: Output, —: No output or N/A

| Format of the signals recorded on the tape | | Output jacks | | | |
|--|-------------|----------------------|-----|-----------------|------------------------|
| | | i HDV/DV | | COMPONENT OUT | VIDEO/S VIDEO |
| | | Output signal format | | | |
| | | DVCAM/DV | HDV | | |
| HDV | 1080/60i | ○ | ○ | ○ ¹⁾ | ○ (480i) ²⁾ |
| | 1080/24p | ○ | ○ | ○ ¹⁾ | ○ (480i) ²⁾ |
| | 1080/30p | ○ | ○ | ○ ¹⁾ | ○ (480i) ²⁾ |
| | 1080/50i | ○ | ○ | ○ ¹⁾ | ○ (576i) ²⁾ |
| | 1080/25p | ○ | ○ | ○ ¹⁾ | ○ (576i) ²⁾ |
| | 720/30p/24p | — | — | ○ ¹⁾ | ○ (480i) ²⁾ |
| | 720/25p | — | — | ○ ¹⁾ | ○ (576i) ²⁾ |
| DVCAM/DV (SP) | | ○ | — | ○ | ○ |

1) The format of the picture output from the COMPONENT OUT jacks can be set in [COMPONENT] of [VIDEO OUT] in the [IN/OUT REC] menu (page 51). For details, see the settings for down conversion (page 27).

2) The signals are down converted and output.

For details of the format of signals output from each jack, see the settings for down conversion (page 27).

Notes

- HDV 720/30p/25p/24p signals can be played back but not input/output via the i HDV/DV jack on the unit.
- HDV 720/60p, HDV 720/50p and SD 480p/576p signals cannot be input/output, recorded, or played back on the unit.

Settings for Output Signals from Each Jack

Settings of output signals from the COMPONENT OUT/VIDEO OUT/S VIDEO OUT jacks

Set the output signals in [COMPONENT] of [VIDEO OUT] in the [IN/OUT REC] menu (page 51).

| [60i/50i SEL] | Format of the original signals | Setting of the [COMPONENT] menu | Format of the signals output from each jack | |
|---------------|--|---------------------------------|---|-----------------------|
| | | | COMPONENT OUT | VIDEO/S VIDEO |
| 60i | HDV 1080/60i HDV 1080/24p HDV 1080/30p HDV 720/24p ¹⁾ HDV 720/30p ¹⁾ | 480i | 480/60i ²⁾ | 480/60i ²⁾ |
| | | 480p/480i | 480/60p ²⁾ | |
| | | 1080i/480i | 1080/60i | |
| | DVCAM/DV 480/60i or S VIDEO/VIDEO input | 480i | 480/60i | 480/60i |
| | | 480p/480i | | |
| | | 1080i/480i | | |
| 50i | HDV 1080/50i HDV 1080/25p HDV 720/25p ¹⁾ | 576i | 576/50i ²⁾ | 576/50i ²⁾ |
| | | 576p/576i | 576/50p ²⁾ | |
| | | 1080i/576i | 1080/50i | |
| | DVCAM/DV 576/50i or S VIDEO/VIDEO input | 576i | 576/50i | 576/50i |
| | | 576p/576i | | |
| | | 1080i/576i | | |

1) 720/24p, 720/30p and 720/25p signals cannot be output as 720p signals.

2) You can select from [SQUEEZE], [LETTER BOX] or [EDGE CROP] in [DOWN CONVERT] of [VIDEO OUT] in the [IN/OUT REC] menu (page 51).

Notes

- HDV 720/30p/25p/24p signals can be played back but cannot be input/output via the  HDV/DV jack on the unit.
- HDV 720/60p, HDV 720/50p and SD 480p/576p signals cannot be input/output, recorded, or played back on the unit.

Recording Format and Input/Output Signals

Setting of output signals from the i HDV/DV jack

Set the output signals in [HDV → DV CONV] of [i.LINK SET] in the [IN/OUT REC] menu (page 51).
The setting is available when [HDV/DV SEL] is set to [AUTO] or [HDV].

| Format of the original signals | Setting of the [HDV → DV CONV] menu | Format of signals output from the i HDV/DV jack |
|--|-------------------------------------|---|
| HDV 1080/60i HDV 1080/30p HDV 1080/24p | OFF | Complies with input signals. |
| | DVCAM | DVCAM 480/60i ¹⁾ |
| | DV SP | DV 480/60i ¹⁾ |
| HDV 1080/50i HDV 1080/25p | OFF | Complies with input signals. |
| | DVCAM | DVCAM 576/50i ¹⁾ |
| | DV SP | DV 576/50i ¹⁾ |

1) You can select [SQUEEZE] or [EDGE CROP] in [i.LINK SET] of [VIDEO OUT] in the [IN/OUT REC] menu (page 51).
You cannot set [LETTER BOX] in this menu.

Playback

This section describes the connections and settings for playback and functions such as playback at various speeds, and searching for a specific scene on a recorded tape.

Connections for Playback

Connecting the unit to a monitor without an i.LINK jack

You can connect the unit to a video monitor/recorder without an i.LINK jack. Connect video cables and audio cables as shown below. For each jack, *see page 12*.

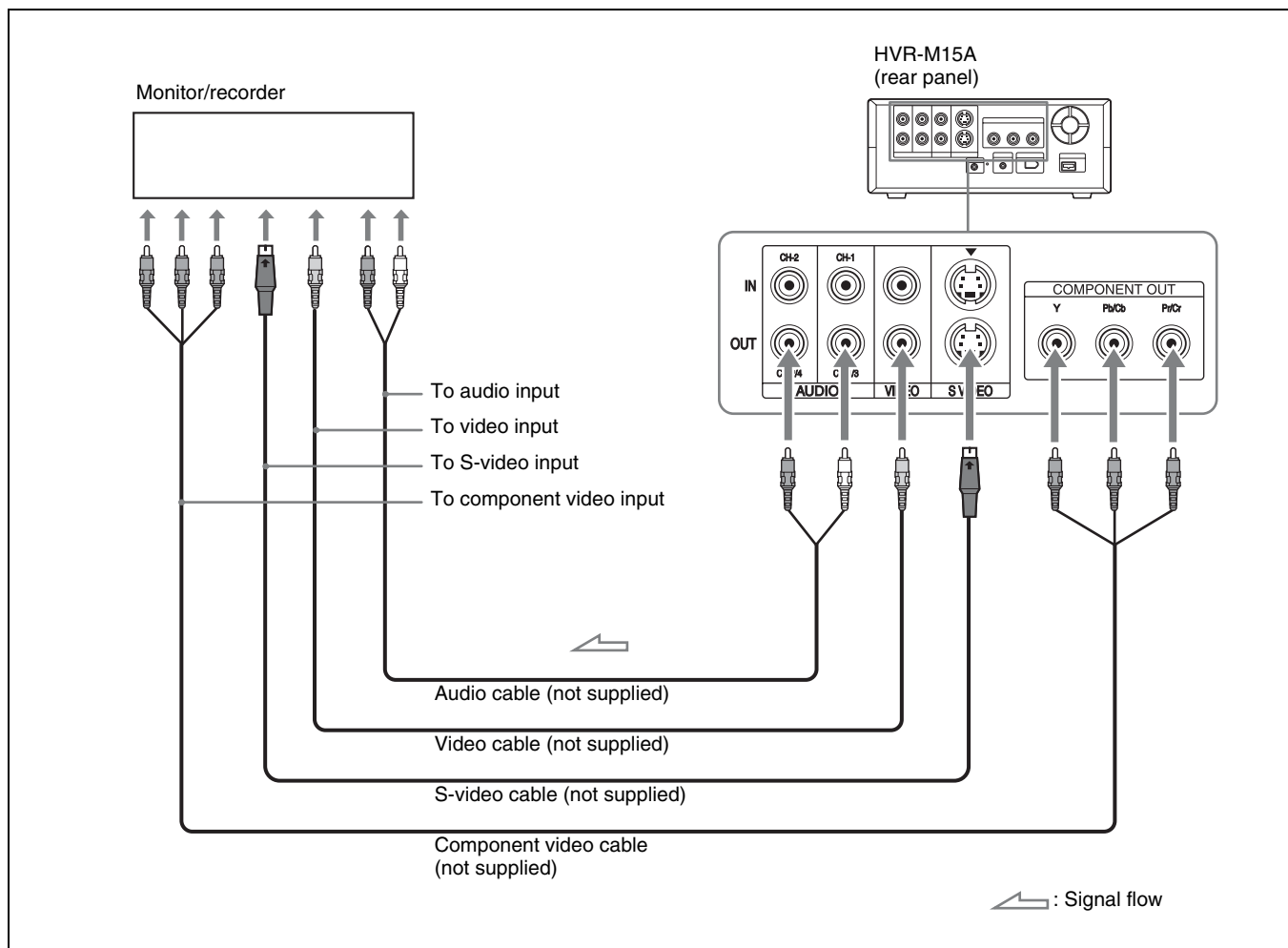

(Continued)

Notes

- To playback an image recorded in HDV format when you connect the monitor using a component video cable, set [COMPONENT] of [VIDEO OUT] in the [IN/OUT REC] menu according to the requirements of your monitor (page 51).
- When an image recorded in DVCAM/DV format is played back, only an image with a quality equivalent to that of the DVCAM/DV format of 480i (NTSC) or 576i (PAL) is output via the COMPONENT OUT jacks, regardless of the [COMPONENT] setting.
- For details on the output level from the COMPONENT OUT jacks, see “Specifications” (page 75).
- To change the output level from the COMPONENT OUT jacks, see [480i LEVEL] in the [IN/OUT REC] menu (page 53).
- There are some restrictions on images output from the COMPONENT OUT jacks of the unit.
Refer to COMPONENT OUT jacks 5 (page 13) of “Location and Function of Parts.”
For more information, see “Recording Format and Input/Output Signals” on page 24.
- If you connect the input connectors of the unit to the output connectors of a monitor, a humming noise may be generated or the image may be distorted. If these phenomena occur, use the INPUT SELECT switch to select a signal that is not being input, or disconnect the cables.
- When you play back an HDV-formatted tape with copyright protected signals or input HDV signals with copyright protection to the  HDV/DV jack, pictures may be output in either 480i (NTSC) or 576i (PAL) format, regardless of the setting of [COMPONENT] of [VIDEO OUT] in the [IN/OUT REC] menu.
- The unit cannot up convert DVCAM/DV recordings to HDV at output.
- When [COMPONENT] of [VIDEO OUT] in the [IN/OUT REC] menu is set to either [1080i/480i] or [1080i/576i], 1080/24p and 1080/30p video signals played back are converted to 1080/60i and 1080/25p video signals are to 1080/50i, and output from the COMPONENT OUT jacks.

Connecting the unit to a monitor equipped with an i.LINK jack

The video and audio signals are sent with hardly any degradation, enabling high-quality playback to a monitor with an i.LINK connector that supports HDV, DVCAM, and DV formats.

For details on i.LINK output formats, see page 72.

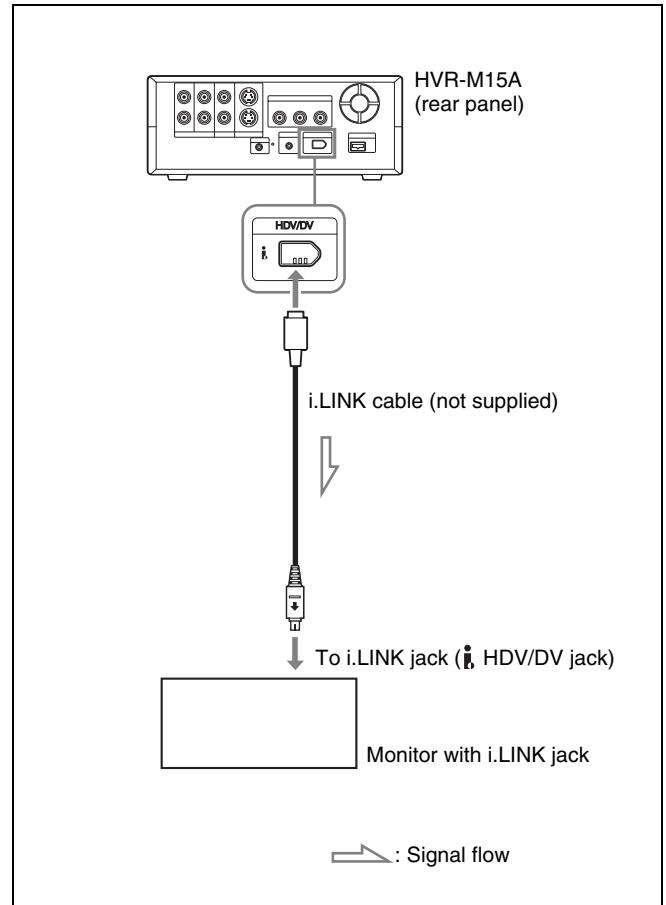

Notes

- Be sure that you set [HDV/DV SEL] in the [IN/OUT REC] menu to [AUTO] (default setting) before connecting the monitor to the unit with the i.LINK cable. If you change the setting after connecting the i.LINK cable, the monitor may not recognize the video signals correctly (page 50).
- To connect the unit to a monitor equipped with an i.LINK jack, you may need to set the monitor so that it recognizes the unit.
For details, refer to your monitor’s instruction manual.
- When an i.LINK connection is made, the unit cannot output video or audio only.

- If you connect the input connectors of the unit to the output connectors of a monitor, a humming noise may be generated or the image may be distorted. If these phenomena occur, use the INPUT SELECT switch to select a signal that is not being input, or disconnect the cables.
- To connect the i.LINK cable between a monitor and the unit, use an HDV or DV-compatible monitor. To play back a tape recorded in the HDV mode on a DV-compatible monitor, set [HDV → DV CONV] of [i.LINK SET] in the [IN/OUT REC] menu to [DVCAM] or [DV SP] before connecting the unit with the i.LINK cable.

For details, refer to your monitor's instruction manual.

- With HDV signals, interlace to progressive or progressive to interlace conversions cannot be made and be output via the **i** HDV/DV jack.
- When HDV signals are down-converted to DVCAM (or DV) format during playback of HDV recorded in progressive and output to the **i** HDV/DV jack, the signals are converted to the interlace system. 1080/24p and 1080/30p are converted to 480i, and 1080/25p to 576i, respectively (*page 28*).
- Some general consumer television sets are provided with a function to control equipment connected with the i.LINK cable. Such a function, however, may not work with the unit.

Settings for Playback

Preparation on the unit

Notes

- Text information is superimposed to the VIDEO OUT jack, S VIDEO OUT jack, and COMPONENT OUT jacks. To output video signals without text data, set the DISPLAY OUTPUT switch to OFF.

For details on the DISPLAY OUTPUT switch, see page 6.

For details on text data, see "Displaying Various Data" on page 18.

- To view a tape recorded in HDV format by connecting the unit to a monitor that has a 4:3 aspect ratio, set [DOWN CONVERT] of [VIDEO OUT] in the [IN/OUT REC] menu to the desired mode (*page 51*).

1 Power on the monitor, then set the monitor's input switch according to the signals input.

2 Turn the unit on.

Playback Procedures

1 Insert a cassette and confirm that the  (cassette) indicator lights.

2 Press the PLAY button on the unit.

The unit starts playback.

To stop playback

Press the STOP button on the unit.

To pause playback

Press the PAUSE button on the unit.

Notes

- During playback, distortion of picture or noise in audio may occur at the portion where the recording format changes.
- You cannot play back an image recorded in DV (LP) mode on the unit.
- If the unit is playing a tape recorded with mixed video signals of the 60i system and 50i system, the picture and sound will be distorted on any portion of a tape where the recording system changes.
- During pause, a picture recorded on a tape in HDV format cannot be output from the **i** HDV/DV jack.

Playback Functions

This section describes useful functions that can be used during playback.

Displaying information (data codes) recorded on a tape

If you record on a tape using a Sony digital HD video camera recorder or digital camcorder, the recording information (data codes) is recorded on the tape. During playback, you can check the recording date and time from the data codes by displaying this information on the unit. Each time you press the DATA CODE button on the Remote Commander, the display switches between no data code display and recording date/time display. Also, you can change the display by setting [DATA CODE] in the [DISPLAY SET] menu. For details, see “DATA CODE” on page 53.

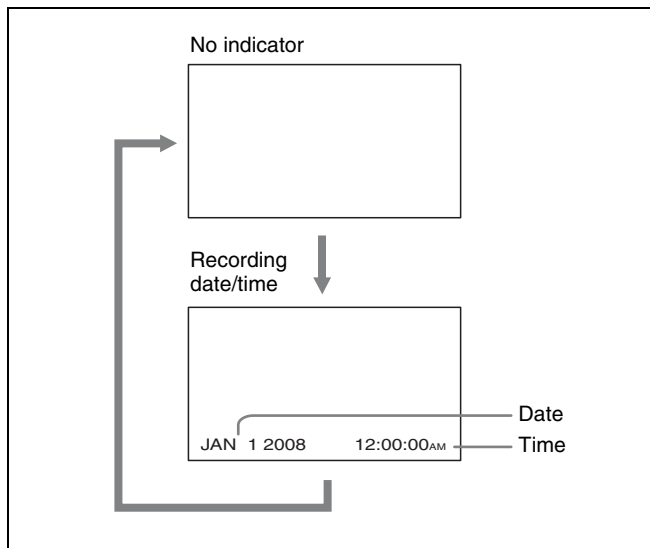

Notes

- If data codes were not recorded, “- - -” appears instead.
- The unit cannot record or play back camera data.

Playing at various speeds

You can playback a tape at various speeds using the Remote Commander.

By using the DSRM-10 remote control unit (not supplied), you can search for pictures while the video is played back at about +24 to -24 times of normal speed.

HDV-formatted tape

| Button | Operation speed | Panel/analog output | | i.LINK output | |
|----------------|---------------------------------|---------------------|-------------------|-------------------|-------------------|
| | | Forward direction | Reverse direction | Forward direction | Reverse direction |
| × 1/10 | One-tenth of normal speed | ⊙ | —* | —* | —* |
| × 1/3 | One-fifth of normal speed | ⊙ | —* | —* | —* |
| × 1 | Playback at normal speed | ⊙ | ○ | ⊙ | ○ |
| × 2 | Playback at normal speed | —* | —* | —* | —* |
| FRAME ◀ ▶ | Frame-by-frame forward scanning | ⊙ | —* | —* | —* |
| ⏮/⏭ | 8× speed | ○ | ○ | ○ | ○ |
| SHUTTLE MAX | 24× speed | ○ | ○ | ○ | ○ |

* The output will be the same as that of ×1.

⊙: Play at normal speed.

○: A rough image is output.

—: No playback takes place.

DVCAM/DV-formatted tape

| Playback options | Operation |
|---|--|
| Play at 1/10 of normal speed | Press the × 1/10 button during playback. |
| Play at 1/3 of normal speed | Press the × 1/3 button during playback. |
| Play at normal speed | Press the × 1 button during playback. |
| Play at twice the normal speed | Press the × 2 button during playback. |
| Play frame by frame | Press the FRAME ◀ ▶ buttons during pause. To play back in the forward direction, press the ▶ button; in the backward direction, press the ◀ button. If you press and hold one of these buttons, playback continues, frame by frame. |
| Fast forward the tape while monitoring pictures | Press the ⏭ button during normal playback or when playing at various speeds. |
| Rewind the tape while monitoring pictures | Press the ⏮ button during normal playback or when playing at various speeds. |
| Play at the maximum speed | Press the SHUTTLE MAX button during playback. |

(Continued)

To change playback direction

Press the FRAME ◀|||/|||▶ buttons during normal playback or when playing at various speeds. To play back in the forward direction, press the |||▶ button; in the backward direction, press the ◀||| button.

Notes

- When the command mode of a Sony device/remote commander is set to VTR4:
 - If you press the ×1/3 button on the supplied Remote Commander while pointing it toward a Sony device other than the unit, the playback speed may turn to 1/5 of normal speed.
 - When you play back a tape in DVCAM/DV format and press the ×1/5 button on the Remote Commander while pointing it toward the unit, the playback speed turns to 1/3 of normal speed.
- If the unit keeps playing at 1/10 of normal speed in forward or reverse for more than 1 minute, the unit begins to play back at normal speed.

To hear the sound while playing at various speeds

To hear the sound while playing at various speeds, set [JOG AUDIO] in the [AUDIO SET] menu to [ON].
For details on the [AUDIO SET] menu, see “AUDIO SET menu” on page 54.

Note

You cannot hear the sound while playing back a tape recorded in HDV format at various speeds.

Searching using the search function

The unit can immediately access the following signals recorded on a tape.

- Searching for the beginnings of the recordings: Index search
- Searching for a point on the tape where the recorded date changes: Date search

To search for scenes, use the supplied Remote Commander.

- 1 Press the SEARCH SELECT button on the Remote Commander to select the search type.

The search type changes in the order of Index search → Date search → (No indication).

When selecting INDEX SEARCH



(The search screens are displayed only on Data display screen.)

- 2 Press the ◀◀◀ / ▶▶▶ button repeatedly to locate the scene you want.

Each time you press the ◀◀◀ / ▶▶▶ button, the unit searches for the previous or next search point. When a search point is located, its number is indicated on the monitor screen. The unit starts searching backwards or forwards until the number comes to zero, then plays back the scene.

How signals are recorded

There are four different signal types, one for each search method; index, title, date, and photo signals. The unit can record either index signals or date signals only on a tape.

Notes

- If you record another program over the beginning of the search signals, you cannot locate the original program.

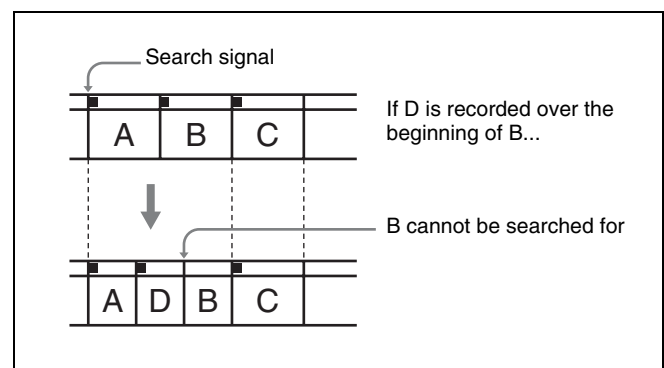

- The interval of a date or index must be 2 minutes or more. If the interval is short, the search signals may not be detected correctly.
- If non-recorded portions are included in the middle of a tape, signal search may not be performed correctly.
- You cannot add search signals after recording.

- The unit does not support searching, reading, or writing of data on cassette memory. For duplicating with the DSR-25/45/50, see “Cassette memory” on page 20.
- Searching may not be done correctly if the tapes were not recorded on Sony-brand digital video equipment.

Auto Repeat

The unit can repeat playback of all or a part of a tape.

To set AUTO REPEAT

- 1 Set [AUTO REPEAT] in the [VTR SET] menu to [ON].
- 2 Press the REW button. (If the tape is already rewound, press the PLAY button.)

The unit rewinds the tape to its beginning and starts playback automatically.

When the following items on the tape are searched for, the unit rewinds the tape to its beginning and starts auto repeat playback automatically.

- Index signals
- A portion unrecorded
- A portion recorded in a format set by other than [AUTO] in [HDV/DV SEL] in the [IN/OUT REC] menu
- Tape end

Auto Repeat using an external AC timer

By connecting the unit to an external AC timer (not supplied), you can repeat playback automatically at the preset time.

- 1 Connect the unit to an external AC timer (not supplied).

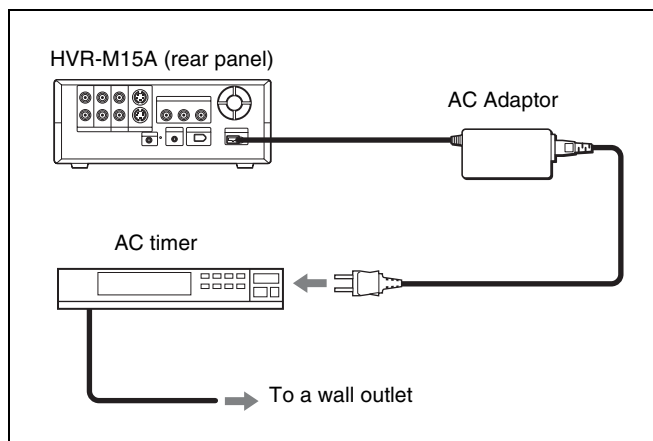

- 2 Set [AUTO REPEAT] in the [VTR SET] menu to [ON].

↺ is displayed on the Data display screen (page 18).

- 3 Set the start time on the external AC timer.

At the preset time, the power of the unit turns on, and after a few to several tens of seconds, auto repeat playback starts automatically. When the following items on the tape are searched for, the unit rewinds the tape to its beginning and starts auto repeat playback automatically.

- Index signals
- A portion unrecorded
- A portion recorded in a format set by other than [AUTO] in [HDV/DV SEL] in the [IN/OUT REC] menu
- Tape end

Notes

- The unit cannot search for an unrecorded portion for 20 seconds at the beginning of the tape until it searches for the next unrecorded portion throughout the tape.
- While a tape is running, be sure not to turn off the power by using an AC timer. The unit and the tape may be damaged. To turn the unit off, press the STOP button on the unit to stop the tape transport operation beforehand.
- The editing software used by a digital non-linear editing system may mark index signals on a tape itself. Therefore, if you use a tape on which signals transmitted from a digital non-linear editing controller are recorded or a copy tape made from one, using digital dubbing, AUTO REPEAT may not be performed correctly.

To stop AUTO REPEAT while the unit is in use
Press the STOP button on the front panel.

To cancel AUTO REPEAT

Set [AUTO REPEAT] in the [VTR SET] menu to [OFF].

Using the Unit as a Videocassette Recorder

This section describes the connections, settings and operations necessary to perform recording on the unit. The same settings and operations apply when you are using the unit for dubbing.

Note

For details on connections of the player and the unit, refer to the instruction manual of the player.

For details, see also page 45 and 46.

Connections for Recording

To video equipment without an i.LINK jack

You can connect the unit to video equipment without an i.LINK jack. Use the unit as a recorder as follows.

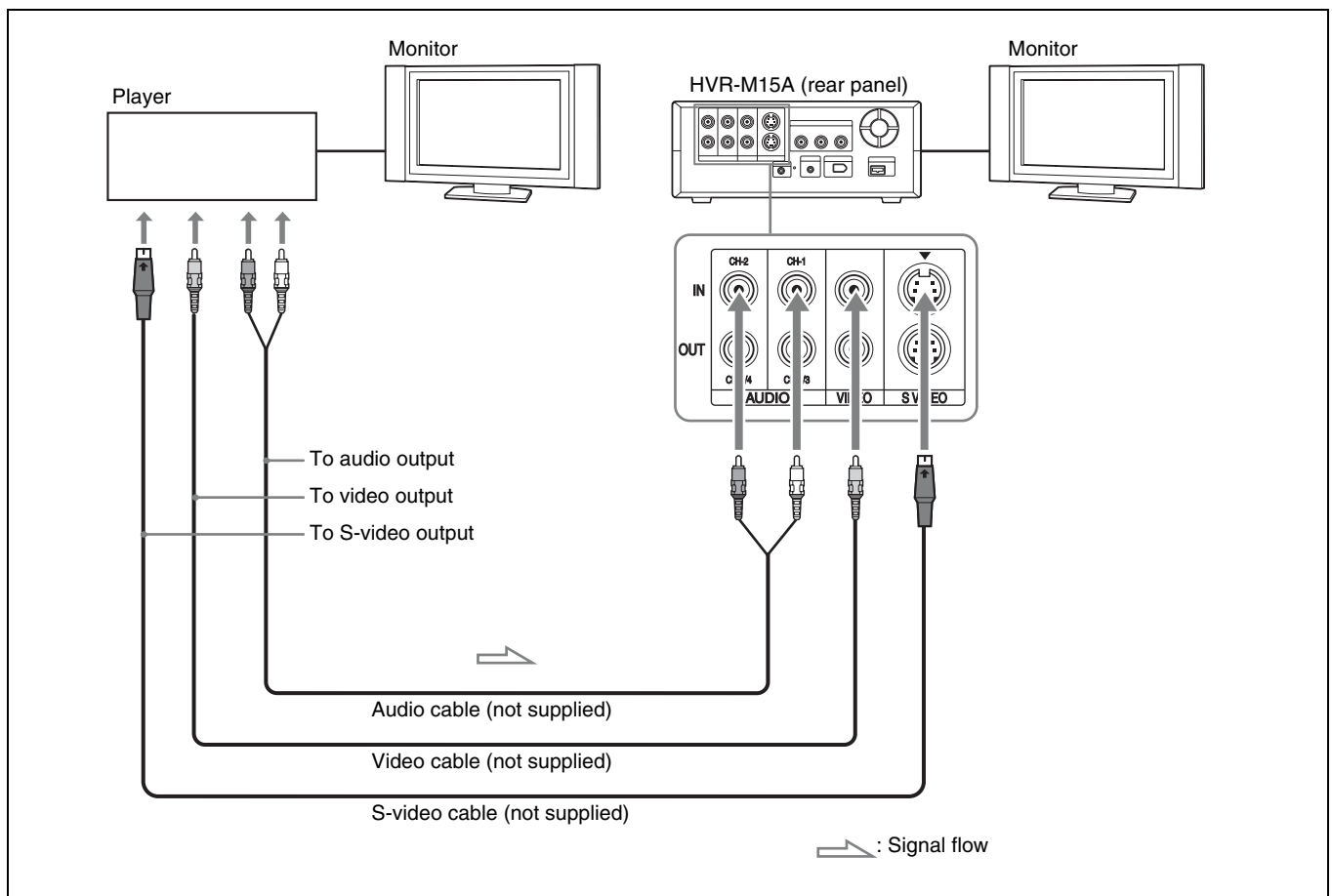

Connect either an S-video cable or a video cable.

Notes

- If you connect the output connectors of the unit to the input connectors of the player, a humming noise may be generated or the image may be distorted. If these phenomena occur, set the INPUT SELECT switch to a position where a signal is not currently being input, or disconnect the cables.
- Distorted signals (i.e., when played back at a speed other than normal) may not be recorded or may be distorted.
- When you connect only AUDIO IN jacks when the HDV indicator is lit, no audio is input. You must connect the VIDEO IN jack at the same time or set [HDV/DV SEL] in the [IN/OUT REC] menu to [DV].

To digital video equipment with an i.LINK jack

When you record an HDV (1080/60i, 1080/24p, 1080/30p, 1080/50i, 1080/25p), DVCAM, or DV format i.LINK signal, the video and audio signals are sent without any degradation in quality, enabling high-quality recording. The signal flow is automatically detected so you do not need to make separate connections for input and output.

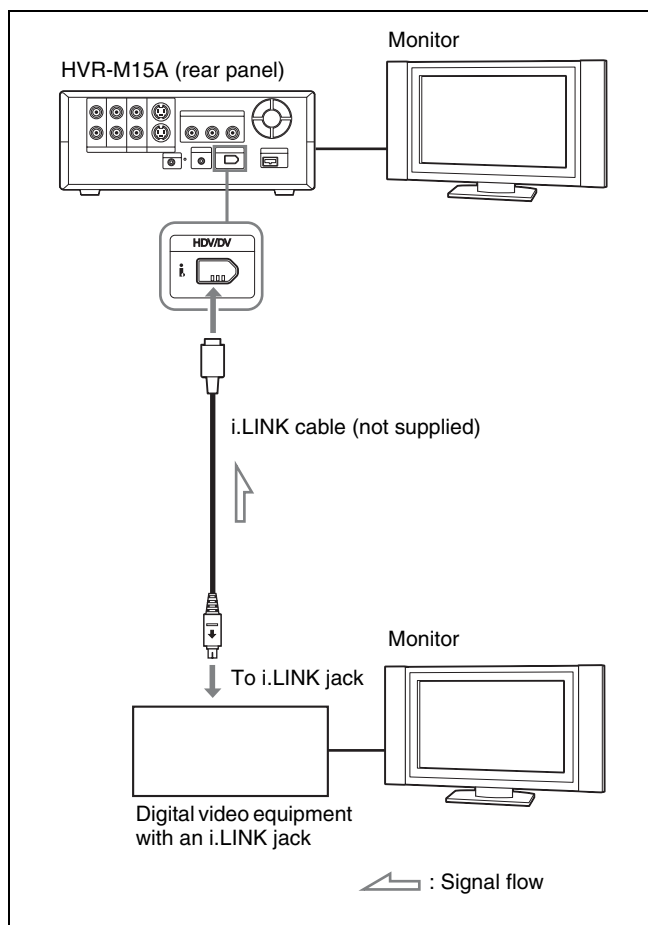
**Notes**

- When you record video from HDV-compatible equipment, set [HDV/DV SEL] in the [IN/OUT REC] menu to [AUTO]. To record video from DVCAM/DV equipment, set [HDV/DV SEL] in the [IN/OUT REC] menu to [AUTO] or [DV] before connecting the i.LINK cable (*page 50*). If you change the setting after connecting the i.LINK cable, the video equipment may not recognize the video signals correctly.
- Copy-protected programs such as digital broadcasts can not be input via the  HDV/DV jack.
- With an HDV/DV connection, the sound is recorded in the same audio recording mode as that of the source tape. To record in a different audio recording mode from that of the source tape, connect the equipment as shown in “To video equipment without an i.LINK jack” on *page 36*.

(Continued)

- With an HDV/DV connection, data codes (recording date/time, camera data) recorded on the source tape are transmitted to the recorder (the unit). As a result, when you play back a recorded tape on the unit and press the DATA CODE button on the Remote Commander, the same data codes as those recorded on the source tape are displayed on the monitor screen.
- If no picture appears via the **i** HDV/DV jack, disconnect the i.LINK cable, then reconnect it.
- The unit cannot record video or audio separately.
- If you record a picture in DVCAM/DV in the playback pause mode, the picture may be rough. When recording is set to HDV, the picture is not recorded.
- If the unit is connected to a device equipped with an i.LINK jack, when you intend to disconnect or reconnect the i.LINK cable, turn off the device and pull out the plug of its power cord from the AC outlet beforehand. If you connect or disconnect the i.LINK cable while the device is connected to the AC outlet, high-voltage current (8 to 40 V) is output from the i.LINK jack of the device to the unit, which may cause a malfunction.
- If you restart recording after a pause or stop, the images recorded before and after restarting operation will not be continuous.
- If you connect the output connectors of the unit to the input connectors of a player or that of a monitor, a humming noise may be generated or the image may be distorted. If these phenomena occur, use the INPUT SELECT switch to select a signal that is not being input, or disconnect the cables.
- The unit cannot record MPEG2 signals except 1080/60i, 1080/24p, 1080/30p, 1080/50i, 1080/25p of HDV.
- When you record HDV signals input from the **i** HDV/DV jack, the connection between the recorded signals pauses for about one second.
- The unit cannot record color bar output in the progressive system. Color bar outputs are recorded in 1080/60i or 1080/50i format according to the setting in [60i/50i SEL] of the [OTHERS] menu (page 58).

Settings for Recording

Preparation on the recorder (the unit)

Notes

- Before recording, set the date and time on the unit so that the recording time can be written into the search signal. You can set the date and time by setting [CLOCK SET] in the [OTHERS] menu (page 58).
- Editing may not be possible with a signal that is copyright protected.
- During recording, the tape transport control buttons (except STOP and PAUSE) are disabled to prevent the tape running mode from being changed by an incorrect operation.

- 1** Turn the power of the monitor on, then set the monitor's input according to the input signals.
- 2** Set up the player to play back a tape.
For details, refer to the instruction manual of the player.
- 3** Turn the unit on.
- 4** When the player is connected to IN jacks on the unit, set [60i/50i SEL] in the [OTHERS] menu according to the input signals (page 58).

When you input 60i system signals, set [60i/50i SEL] to [60i]. When you input 50i system signals, set [60i/50i SEL] to [50i] (page 58).

Notes

- Do not change the [60i/50i SEL] setting during recording.
- When you select S VIDEO or VIDEO with the INPUT SELECT switch, if the field frequency of the input signal is different from that of the [60i/50i SEL] setting, the picture goes blank.

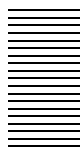

- When the signals are input through the i.LINK interface, the unit detects the field frequency of the input signal automatically. You do not need to change the [60i/50i SEL] setting. When [60i/50i SEL] is set to [50i], however, the time code generated by the unit is fixed to the non-drop frame mode. Even when 60i system signals are input to the i.LINK jack, the time code generated by the unit is the non-drop frame mode, regardless of the [TC FORMAT] setting in the [TC/UB SET] menu. To record in the drop frame mode, set [60i/50i SEL] to [60i].

5 Select input signals by switching the INPUT SELECT switch on the unit.

HDV/DV: to record input signals from the HDV/DV jack

S VIDEO: to record input signals from the S VIDEO IN jack

VIDEO: to record input signals from the VIDEO IN jack

You need to adjust [HDV/DV SEL] (page 50) and [REC MODE] (page 50) in the [IN/OUT REC] menu to the desired recording format.

For details on recording tape formats, see page 73.

Notes

- Do not change the INPUT SELECT switch setting during recording. If you change the setting of this switch during recording, recording will stop for several seconds. Recording will restart after the internal circuits are switched. During this time, no image is recorded.
- When DVCAM/DV signals which are input from the HDV/DV jack, or video signals which are from the VIDEO IN jacks or S VIDEO IN jacks, are output to each analog output jack, the distortion of the video signals occurs at the bottom of the TV monitor display due to the jitter. Depending on the display area of the TV monitor you have, the distortion of the picture may appear at the bottom of the screen. This is not a malfunction.
Pictures may be distorted or not be displayed depending on the TV monitors. This will not appear while recording with the unit.
Be aware of these phenomena when you connect other recording device via the analog jacks of the unit.

- Depending on the TV monitor being connected, the screen may blink or be distorted when DVCAM/DV signals which are input from the HDV/DV jack, or video signals which are from the VIDEO IN jacks or S VIDEO IN jacks, are output to the VIDEO OUT jacks.
Be aware of these phenomena when you connect other recording device to these jacks. This will not appear while recording with the unit.

6 Select the audio mode. (With an HDV/DV connection, skip this step.)

When you select S VIDEO or VIDEO with the INPUT SELECT switch, set the audio mode by setting [AUDIO MODE] in the [AUDIO SET] menu (page 54).

FS32K: Switches the audio mode to 4-channel mode

FS48K: Switches the audio mode to 2-channel mode

When recording a tape in DV (SP), you can set [AUDIO LOCK] in the [AUDIO SET] menu (page 54).

Note

When signals are input from the HDV/DV jack, the audio mode is the same as the one used to input signals from the player.

7 Select the recording level adjustment mode using [AUDIO AGC] in the [AUDIO SET] menu.

Notes

- You cannot adjust the recording level if you record signals input via the HDV/DV jack.
- For connecting the unit to a device that does not have an i.LINK jack, the sound is recorded on CH1/2 when the audio mode is set to [FS32K] (4-channel mode).

(Continued)

Using the Unit as a Videocassette Recorder

- 8** Adjust the audio recording level with [AUDIO REC LV] in the [AUDIO SET] menu, if necessary (page 54).

You can adjust [AUDIO REC LV] only when you have selected [OFF] in step 7.

Adjust not to reach the maximum value of the audio level meter even when the audio is at the maximum volume. When the meter turns red, the sound will be distorted.

Notes

- When the unit records in DVCAM (DV) format, it supports two audio modes, with either 2-channels at FS48K or 4-channels at FS32K. It is not possible to select other modes (for example with 2-channels at FS32K).
- During recording, you cannot change the audio mode.
- If you intend to dub audio after recording, select whether [DVCAM] or [DV SP] of [REC MODE] in the [IN/OUT REC] menu according to the unit you will use for audio dubbing. Then, set [AUDIO MODE] in the [AUDIO SET] menu to [FS32K] (4-channel mode) before recording (page 54). (The unit does not have an audio dubbing function.)

Recording Procedures

This section describes the procedures used to record signals sent from another VCR to the unit.

For details on operation when the unit is connected to a computer via the  HDV/DV jack, refer to “Editing (Connecting a Computer)” on page 45.

- 1** Insert a cassette and confirm that the  (cassette) indicator lights up.
- 2** Press the playback button on the player.

The player starts playback.
- 3** On the unit, press the PLAY button while holding the REC button down.

Note

When the unit records HDV format images, it takes a while until recording starts. This delay, however, is not an error. ([STBY] is displayed on the screen and the REC indicator blinks until recording starts.)

To stop recording

Press the STOP button on the unit.

To pause recording

Press the PAUSE button on the unit.

Note

You cannot up convert NTSC or PAL signals in the HDV format for recording.

Recording Functions

Marking an index

By pressing the INDEX button on the unit or the INDEX MARK button on the Remote Commander during recording, you can mark an index signal at any place on the tape. If you mark an index at a scene you want to be able to search for, you can easily find the scene later. When [AUTO INDEX] in the [VTR SET] menu is set to [ON] (page 55), if you start recording while the tape is stopped, the unit automatically marks an index. While the index is being marked, the  indicator appears for about seven seconds on the Data display screen (page 18).

Notes

- You cannot mark a new index while the  indicator is being displayed.
- If you record on a portion of the tape where an index has been marked, the index will be erased. You cannot delete just an index while keeping the image or sound.
- You cannot mark an index during playback or audio dubbing operations. The INDEX button and the INDEX MARK button are disabled in these operations.

To use an index during playback

See “Searching using the search function” on page 34.

Dubbing/Editing

Dubbing to Other Equipment

This section describes the connections and settings necessary to perform dubbing on other equipment, using the unit as a video player.

Connections for Dubbing

To digital video equipment with an i.LINK jack

Connect the unit to the recorder as shown on the right using an i.LINK cable.

The signal flow is automatically detected so you do not need to make separate connections for input and output. Also, by connecting the unit to an editing controller via the **i** HDV/DV jack, you can configure a digital non-linear editing system.

For connections of the editing controller and the unit, refer to the editing controller instruction manual.

Before dubbing, you must set the format in which you want to output signals. Make [HDV/DV SEL] (page 50) and [i.LINK SET] (page 51) settings in the [IN/OUT REC] menu.

For details, refer to “Major Differences among HDV1080i, DVCAM, and DV Formats” on page 24.

For details on i.LINK output formats, see page 72.

To dub a tape recorded in HDV format using the duplicate function on other units such as the DSR-25/45/50, select [DVCAM] in [HDV → DV CONV] of [i.LINK SET] in the [IN/OUT REC] menu.

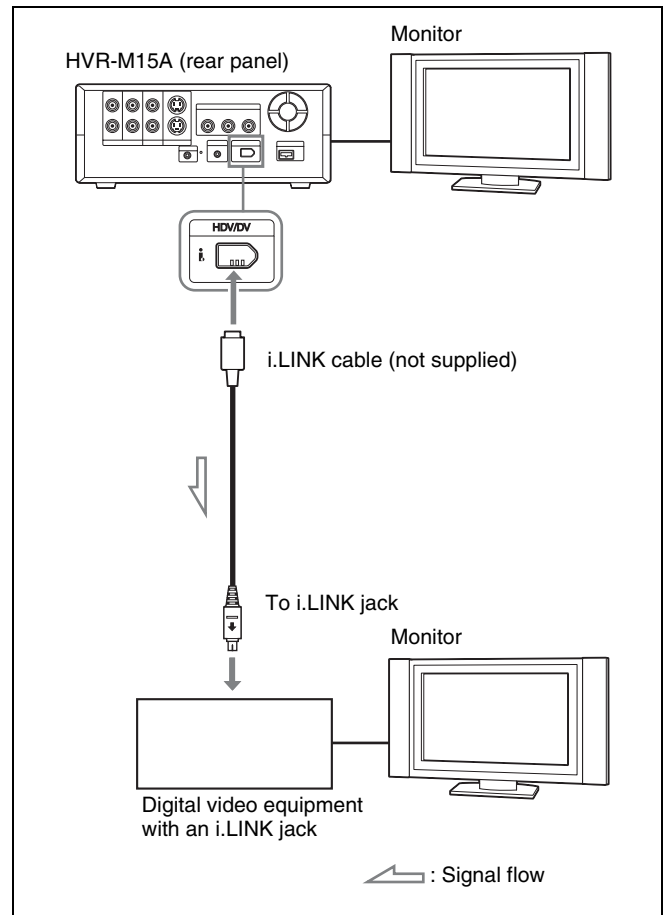

There are some limitations to down converting a tape recorded in HDV format to DVCAM format.
For details, see “i.LINK SET” in the “IN/OUT REC” menu on page 51.

(Continued)

Dubbing to Other Equipment

Notes

- If you output pictures in the playback pause mode when using an i.LINK connection, recorded images may appear distorted.
- When the tape is recorded in HDV format, the picture is output as a simplified picture during playback at various speeds (*page 33*).
- When using an i.LINK connection, you cannot output only pictures or sounds separately.
- When progressive HDV signals are played back and down converted into DVCAM (or DV) format to output to i.LINK connection, the signals are converted to interlace system. 1080/24p and 1080/30p are converted to 480i, and 1080/25p to 576i, respectively.

To video equipment without an i.LINK jack

When connecting the unit to a recorder without an i.LINK jack, connect the two devices as follows. Set [COMPONENT] and [DOWN CONVERT] of [VIDEO OUT] in the [IN/OUT REC] menu (*page 51*) depending on the signals you wish to output.

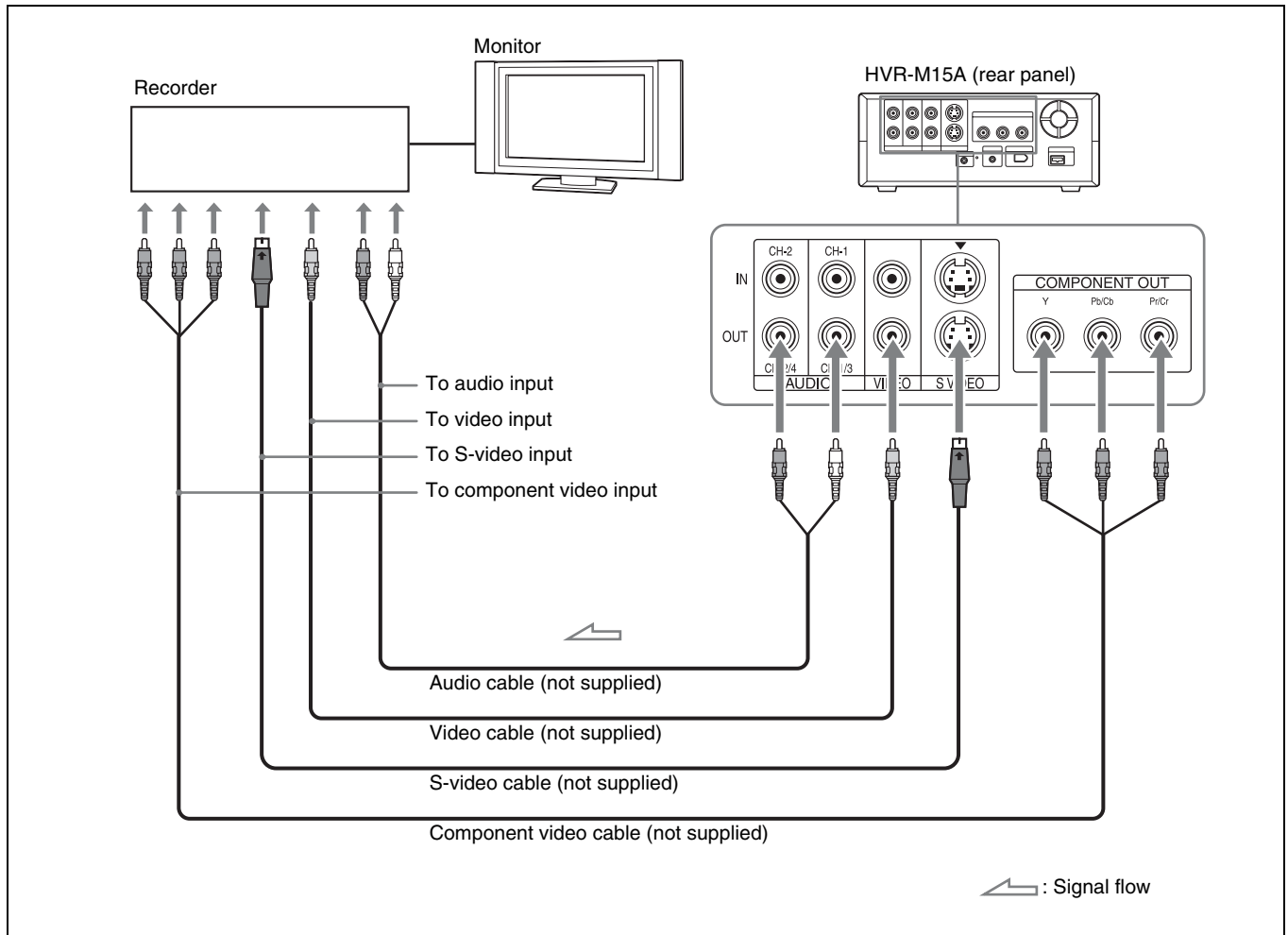

Notes

- See also "Notes" on (*page 30*).
- The audio output signal is selected by the setting of [AUDIO MIX] in the [AUDIO SET] menu.

Dubbing Procedures

1 Prepare the unit.

Refer to “Settings for Playback” on page 31.

2 Prepare the recorder.

If the recorder has an input selector switch, select an input.

For details, refer to your recorder’s instruction manual.

3 Start playback on the unit and start recording on the recorder.

Refer to “Playback Procedures” on page 31.

For details, refer to your recorder’s instruction manual.

4 When dubbing is finished, stop recording on the recorder, and then stop playback of the unit.

Editing (Connecting a Computer)

You can set up an editing system by connecting the unit to a computer (editing machine) using the **i** HDV/DV jack (i.LINK connection) on the unit.

The unit can output HDV 1080/24p, 1080/30p, or 1080/25p (progressive) signals without conversion only via an i.LINK connection.

For details on the connection to the editing machine, refer to the supplied instruction manual of your editing unit.

The editing functions you can use depend on the editing software. For details on editing methods, refer to the instruction manual of your editing software.

Connecting the Unit to a Computer

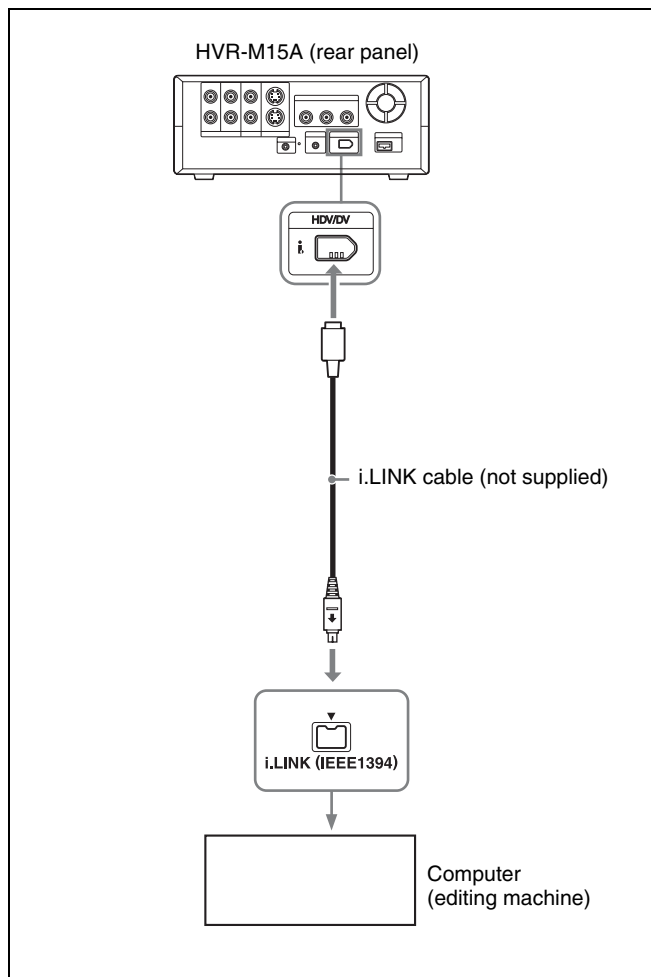

Notes

- Be sure to connect the i.LINK cable to the computer (editing machine) first and then connect it to the unit. If you connect the i.LINK cable to the unit first, it may cause the unit to malfunction because of static electricity.
- When the unit is connected to a computer equipped with an i.LINK jack and you intend to disconnect or reconnect the i.LINK cable, turn off the computer and pull out the plug of its power cord from the wall outlet beforehand. If you connect or disconnect the i.LINK cable while the computer is connected to the AC outlet, high-voltage current (8 to 40 V) is output from the i.LINK jack of the device to the unit, which may cause a malfunction.
- Before connecting the i.LINK cable, set [HDV/DV SEL] and [i.LINK SET] in the [IN/OUT REC] menu. If you perform the settings after connecting the cable, the computer (editing machine) may not recognize the unit correctly or may freeze.
- If you input or output signals in a format incompatible with the computer (editing machine), the computer may not recognize the unit correctly or may freeze.
- When set to EE mode, the unit outputs analog signals that are input from the **i** HDV/DV jack to the computer. S VIDEO or VIDEO signals are output from the **i** HDV/DV jack, according to the setting of the INPUT SELECT switch. To output the playback image from the unit through the **i** HDV/DV jack only, set the INPUT SELECT switch to HDV/DV.

Preparations

Transferring picture data from the unit to a computer (editing machine)



- To transfer picture data recorded on a tape to an editing machine in HDV, set [HDV/DV SEL] in the [IN/OUT REC] menu to [HDV] (page 50), then set [HDV → DV CONV] of [i.LINK SET] in the [IN/OUT REC] menu to [OFF] (page 51).
- To transfer the picture data recorded on a tape in DVCAM (DV) to an editing machine, set [HDV → DV CONV] of [i.LINK SET] in the [IN/OUT REC] menu to [OFF] (page 51).
- To transfer the picture data recorded on a tape in HDV to an editing machine in DVCAM (DV) format, select [DVCAM] or [DV SP] in [HDV → DV CONV] of [i.LINK SET] in the [IN/OUT REC] menu, then set [DOWN CONVERT] (page 51).

Notes

- The operation may not work with some of editing machine software. Before using the software, confirm that it is compatible with the unit.
- The unit cannot up convert a tape recorded in DVCAM (DV) format to HDV format when transferring the picture data on an editing machine.
- If you use a tape recorded both in HDV and DVCAM (DV) formats when [HDV/DV SEL] in the [IN/OUT REC] menu is set to [AUTO], the computer (editing machine) may not recognize the unit or you may not be able to edit the tape correctly.
- There are restrictions on the video output when you play back a tape recorded in HDV format at various speeds. Refer to the table for “HDV-formatted tape” in “Playing at various speeds” (page 33).
- When you use a tape that was down converted from HDV to DVCAM or DV, some conventional DVCAM/DV editing software may not perform a time code search, or this operation could result in an error.
- When you record HDV signals that are input through the  HDV/DV jack, the connecting portion between scenes on the tape will be displayed as a still picture for approximately 1 second. We recommend you perform digital nonlinear editing.

- If your editing software has the capability to output the time code as well as the video and audio signals to the unit, and you intend to record that time code, set [HDV/DV IN TC] in the [TC/UB SET] menu of the unit to [EXTERNAL].

For details on the TC/UB SET menu, see “TC/UB SET menu” on page 56.

- When [HDV/DV IN TC] in the [TC/UB SET] menu is set to [EXTERNAL], if you input time code to the  HDV/DV jack that is not continuous or does not advance correctly, the value of the recorder or displayed time code may not be equal to the actual value of the input one. If you use a tape recorded under such conditions, you may not be able to perform searches or edits of the picture, depending on the device you use.
- For connection of the editing controller and its peripheral devices, refer to the instruction manual of the editing controller and that of the editing software you use.
- The editing functions you can use depend on the editing software. For details on editing methods, refer to the instruction manual of your editing software.
- The unit has a function to down convert HDV signals to DVCAM (DV) signals to output them from the  HDV/DV jack. Some software may not edit DVCAM/DV signals that are down converted from HDV signals correctly. In this case, follow the procedures below for tape duplication, then use the duplicated tape when editing the picture.

Creating a DVCAM compatible tape

Set [HDV → DV CONV] of [i.LINK SET] in the [IN/OUT REC] menu to [DVCAM], then perform DVCAM recording using a recording device that accepts the DVCAM format.

Creating a general consumer DV compatible tape

Set [HDV → DV CONV] of [i.LINK SET] in the [IN/OUT REC] menu to [DV SP], set [DOWN CONVERT], then perform DV recording using a recording device that accepts DV format.

Transferring picture data from a computer (editing machine) to the unit

- To transfer data from a computer (editing machine) in HDV format, set [HDV/DV SEL] in the [IN/OUT REC] menu to [HDV] (*page 50*).
- To transfer data from a computer (editing machine) in DVCAM (DV) format, set [HDV/DV SEL] in the [IN/OUT REC] menu to [DV] (*page 50*). Then, according to the desired recording format, set [REC MODE] to [DVCAM] or [DV SP] (*page 50*).

Note

Before connecting the unit to a computer (editing machine), set [HDV → DV CONV] of [i.LINK SET] in the [IN/OUT REC] menu to [OFF] for HDV or to [DVCAM]/[DV SP] for DVCAM (DV) (*page 51*).

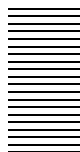

Adjusting and Setting Through Menus

Operating Menus

The unit allows you to set various parameters in the menus. Before you start using the unit, set the internal clock in [CLOCK SET] in the [OTHERS] menu. Except for clock setting, you can use default settings for all other parameters as they are, and change them as needed.

Notes

- Do not pull out the power cord plug while operating the menus. Otherwise, the settings of the menu may be changed accidentally.
- If the internal backup battery is exhausted, the time set in the internal clock, the [60i/50i SEL] setting, and the time code of the [FREE RUN] setting will be initialized. The internal backup battery is fully charged if you connect the power to the unit for about 24 hours. A fully charged internal battery can run for about 1 month.

Changing a menu setting

- 1** Press the MENU button.
- 2** Pressing the \uparrow/\downarrow buttons, select the menu icon you want to change, then press the EXEC button.
- 3** Pressing the \uparrow/\downarrow buttons, select the submenu you want to change, then press the EXEC button.
- 4** Pressing the \uparrow/\downarrow buttons, change the setting.
- 5** Press the EXEC button to return to the submenu.
- 6** Repeat steps **1** to **5**, as needed.

To return to the previous menu level, press the \uparrow/\downarrow buttons and select [↩ RETURN].

You can use the \leftarrow/\rightarrow buttons to move the menu cursor and to adjust or increase/decrease setting values.

Menu Structure

The menu of the unit consists of the following menus and submenus.

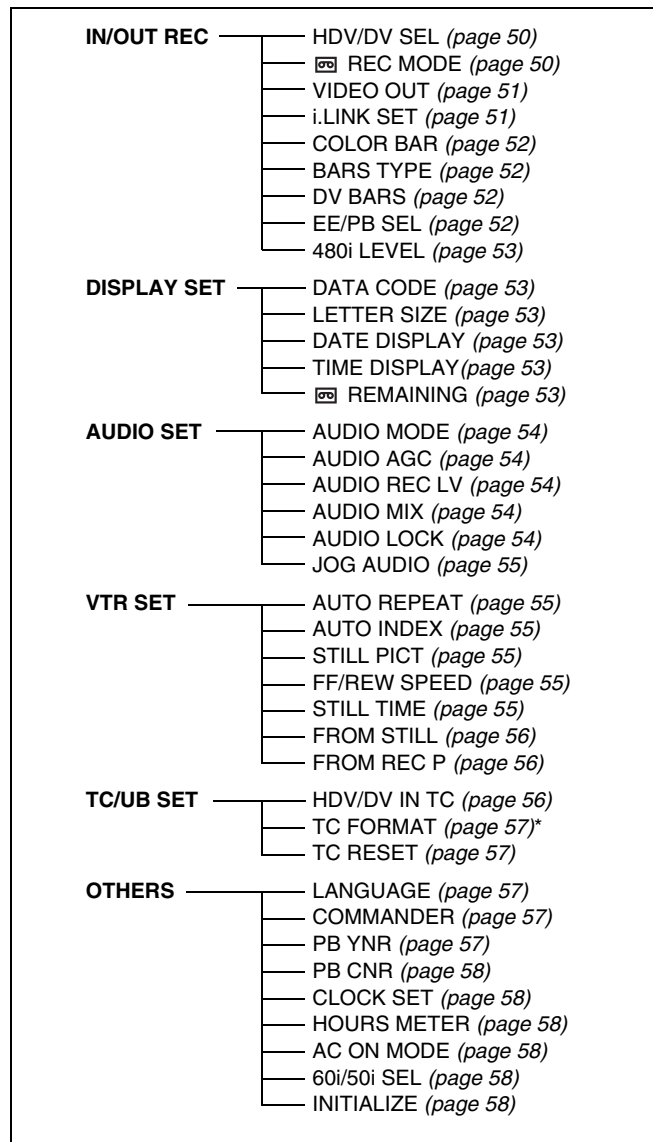







* available only when you use a 60i signal

Operating Menus

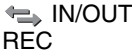



Menu Contents

Default settings are indicated with rectangles.

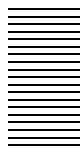
IN/OUT REC menu







| Icon/Menu | Submenu | Setting |
|---|--|---|
|  IN/OUT REC | HDV/DV SEL <i>(pages 30, 37, 41, 45)</i> | <p>Normally, set this menu to [AUTO]. Select this menu when you want to limit the output format during tape playback or limit the signals to be input or output from the  HDV/DV jack. This setting will affect analog outputs.</p> <p>► AUTO : Automatically switches signals to HDV format or DVCAM/DV format during tape playback. When an i.LINK cable is connected, signals in HDV format or DVCAM/DV format will be switched automatically and signals from the  HDV/DV jack will be input/output for recording/playback.</p> <p>HDV : Outputs portions of signals recorded in HDV format during tape playback. When an i.LINK cable is connected, only signals in HDV format from the  HDV/DV jack will be input/output for recording/playback. Also, select this setting when the unit is connected via an i.LINK cable to a computer supporting HDV format (<i>see pages 37, 41</i>).</p> <p>DV : Outputs signals of portions recorded in DVCAM/DV format during tape playback. When an i.LINK cable is connected, only signals in DVCAM/DV format from the  HDV/DV jack are input or output for recording/playback. Also select this setting when the unit is connected via an i.LINK cable to a computer that supports DV format (<i>see pages 37, 41</i>).</p> <p>Notes</p> <ul style="list-style-type: none"> • Before changing the setting, be sure to disconnect the i.LINK cable, or turn the other device off. If an i.LINK cable is connected when you change the setting, the video equipment may not recognize the signals correctly. • If you select [AUTO], the screen turns off temporarily when HDV signals are switched to DVCAM/DV signals or vice versa. The video and audio also stops at the same time. • For details on the i.LINK output and the recording tape format, <i>see pages 72 and 73</i>. |
| |  REC MODE <i>(pages 39, 47)</i> | <p>Switches the recording mode between DVCAM and DV format (SP mode only).</p> <p>► DVCAM : Records in DVCAM format. DV SP : Records in DV format (SP mode).</p> <p>Note</p> <p>You cannot change the setting during recording.</p> |

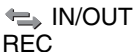

| Icon/Menu | Submenu | Setting |
|---|------------------------------|---|
|  IN/OUT REC | VIDEO OUT (page 27) | <p>Selects the mode of the COMPONENT OUT jacks.</p> <p>COMPONENT Selects the output format from the COMPONENT OUT jacks. Select from [480i], [480p/480i], or [1080i/480i] when [60i/50i SEL] in the [OTHERS] menu is set to [60i]. Select from [576i], [576p/576i], or [1080i/576i] when [60i/50i SEL] in the [OTHERS] menu is set to [50i].</p> <p>DOWN CONVERT Selects the setting for down converting images output from the COMPONENT OUT jacks and analog video jacks when playing back HDV format or inputting HDV signals from the  HDV/DV jack.</p> <p>▶ SQUEEZE : Maintains the image vertically and horizontally by compressing the horizontal ratio. Images appear vertically long.</p> <p>▶ LETTER BOX : Maintains the aspect ratio of the image by compressing the image vertically.</p> <p>▶ EDGE CROP : Maintains the original image size and crops the left and right edges of the images.</p> <p>Notes</p> <ul style="list-style-type: none"> • Regardless of the playback tape or of the format input to the  HDV/DV jack, the selectable setting values displayed on this menu vary depending on the setting of [60i/50i SEL]. • WSS (Wide Screen Signaling) is not output when the picture is output to the COMPONENT OUT jacks in 480p or 576p. Set the monitor according to the down convert format of the picture that is output from the unit. • When you play back a tape in DVCAM (DV) format while an EE picture in NTSC/PAL is displayed, either the 480i resolution or the 576i resolution is output, regardless of the setting of [COMPONENT]. • When you play back an HDV-formatted tape with copyright protected signals or input HDV signals with copyright protection to the  HDV/DV jack, pictures may be output in either 480i (NTSC) or 576i (PAL) format, regardless of the setting of this submenu. |
| | i.LINK SET (pages 28, 45) | <p>Adjusts the down conversion format. This menu is available when [HDV/DV SEL] is set to [AUTO] or [HDV].</p> <p>HDV → DV CONV</p> <p>▶ OFF : Disables down conversion.</p> <p>▶ DVCAM : Down converts to DVCAM format.</p> <p>▶ DV SP : Down converts to DV SP format.</p> <p>DOWN CONVERT This setting is available when [HDV → DV CONV] is set to [DVCAM] or [DV SP].</p> <p>▶ SQUEEZE : Plays back with a compressed horizontal screen image and maintains all images on display. Images appear vertically long.</p> <p>▶ EDGE CROP : Plays back with both left and right sides of the screen images cut off and maintains the original image appearance.</p> <p>Notes</p> <ul style="list-style-type: none"> • When [DVCAM] is selected, there are some limitations, as described below. <ul style="list-style-type: none"> – ATN (Absolute Track Number) outputs the value counted in DVCAM format during playback at regular speed (×1) or recording of the internal color bars only. During playback at irregular speeds other than those described above, ATN outputs the value of a tape recorded in HDV format. – When the unit is playing back at regular speed (×1) and detects a blank portion on the tape, the unit counts the blank portion as ATN-formatted in DVCAM. – When using a duplicating function that is equipped with a device such as the DSR-25/45/50, select [DVCAM]. – Please note that a duplicated tape and the source tape recorded in HDV format with [DVCAM] selected do not share the same ATN (Time code value is displayed correctly). • When you change the video format setting of [DOWN CONVERT] of [i.LINK SET] in the [IN/OUT REC] menu, the video signal output from the COMPONENT OUT jacks, S VIDEO OUT jack, or VIDEO OUT jack may be distorted for a moment. • Before changing your setting, be sure to disconnect the i.LINK cable. If you change the setting while i.LINK is connected, the video device may not recognize the new setting. |



(Continued)

Operating Menus

| Icon/Menu | Submenu | Setting |
|---|-----------------------|---|
|  IN/OUT REC | COLOR BAR | <p>Selects whether to display color bars or not. Also, you may select color bars with or without tone signals (1 kHz full bit –20 dB at 60i, 1 kHz full bit –18 dB at 50i).</p> <p>▶ OFF : Does not display color bars and no tone signals. ON : Displays color bars without tone signals. ON[TONE] : Displays color bars with tone signals.</p> <p>Notes</p> <ul style="list-style-type: none"> • Color bars and tone signals are output from the  i.LINK, HDV/DV jack, COMPONENT OUT jacks, and analog output jacks. • Color bars and tone signals cannot be output when the tape is in playback mode. • The color bars output to i.LINK/the color bars and tone signals recorded on tapes/the format of tone signals can be set by [HDV/DV SEL] and [ REC MODE]. <ul style="list-style-type: none"> – When [HDV/DV SEL] is set to [AUTO], the format of the color bar and tone signals will be output/recorded according to the video format displayed in “1 Format indicator” (page 18) of the text data display on a monitor. – When [HDV/DV SEL] is set to [HDV], color bars and tone signals are output/recorded in HDV format. – When [HDV/DV SEL] is set to [DV] and [ REC MODE] in the [IN/OUT REC] menu is set to [DVCAM], color bars and tone signals will be output/recorded in DVCAM format. – When [HDV/DV SEL] is set to [DV] and [ REC MODE] in the [IN/OUT REC] menu is set to [DV SP], color bars will be output/recorded in DV (SP) format. • Color bar outputs cannot be recorded in progressive but are recorded in 1080/60i or 1080/50i format according to the setting of [60i/50i SEL] in the [OTHERS] menu (page 58). • When the unit is turned off and on again, [COLOR BAR] is automatically set to [OFF]. |
| | BARS TYPE | <p>Selects the type of color bars.</p> <p>TYPE 1 : Outputs TYPE 1 color bars. ▶ TYPE 2 : Outputs TYPE 2 color bars. TYPE 3 : Outputs TYPE 3 color bars.</p> <p>Notes</p> <ul style="list-style-type: none"> • When color bars are output in NTSC (60i) mode on the unit, no-setup (0 IRE) signals are output. • Even when the unit's screen aspect ratio displays at 4:3, the color bars are generated as 16:9. When an edge cropped (4:3) picture of a color bar is output in HDV format, or when [DV BARS] is set to [4:3] in DV format, select [TYPE 2]. • Color bars on the unit are generated in HDV (1080i) resolution. When a resolution other than HDV (1080i) is output, the color bars are down converted and output. The transition edges between the color bars are distorted. • You cannot change the current setting during recording. |
| | DV BARS | <p>Selects the aspect ratio of color bars set in [BARS TYPE] (DVCAM/DV (SP) format only).</p> <p>▶ 16:9 : Sets the aspect ratio of color bars to 16:9. 4:3 : Sets the aspect ratio of color bars to 4:3.</p> <p>Note</p> <p>You cannot change the current setting during recording.</p> |
| | EE/PB SEL (page 8) | <p>Sets the stop, fast-forward, and rewind modes.</p> <p>▶ EE : Outputs EE picture and EE sound. PB : Mutes the image and sound.</p> <p>Note</p> <p>Even [PB] is selected, when you press REC button:</p> <ul style="list-style-type: none"> – EE pictures and EE sounds are output. – When [HDV/DV IN TC] in the [TC/UB SET] menu is set to [EXTERNAL], and the INPUT SELECT switch is set to HDV/DV, the time code of the other device connected to the  i.LINK, HDV/DV jack is displayed on the Data display screen. |

| Icon/Menu | Submenu | Setting |
|-----------------|------------------------------|---|
| ↔ IN/OUT REC | 480i LEVEL (pages 13, 30) | <p>Selects the component output level of luminance and chrominance from either BETACAM or SMPTE signals when the component output is set to 480i.</p> <p>▶ BETACAM : Sets the COMPONENT OUT jacks to BETACAM level.</p> <p>▶ SMPTE : Sets the COMPONENT OUT jacks to SMPTE level.</p> <p>Note For details on COMPONENT OUT jack specifications, see page 76.</p> |

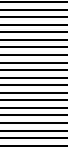

DISPLAY SET menu

| Icon/Menu | Submenu | Setting |
|---|--|--|
|  DISPLAY SET | DATA CODE (page 32) | <p>Selects whether or not to display the data codes on the analog video output.</p> <p>▶ OFF : Does not display the data codes.</p> <p>▶ DATE : Displays the date and time when recorded.</p> |
| | LETTER SIZE | <p>Selects the character size of the menu at the cursor.</p> <p>▶ NORMAL : Normal size</p> <p>▶ 2 x : Double height size</p> |
| | DATE DISPLAY | <p>Selects the date display in the data code display.</p> <p>▶ Y/M/D : Displays YY/MM/DD (year/month/day).</p> <p>▶ M/D/Y : Displays MM/DD/YY (month/day/year). (Default setting for the HVR-M15AU/M15AN.)</p> <p>▶ D/M/Y : Displays DD/MM/YY (day/month/year). (Default setting for the HVR-M15AE/M15AP.)</p> |
| | TIME DISPLAY | <p>Selects the time display in the data code display.</p> <p>▶ 12H : Displays 12-hour time. (Default setting for 60i)</p> <p>▶ 24H : Displays 24-hour time. (Default setting for 50i)</p> |
| |  REMAINING (page 18) | <p>▶ AUTO : The remaining tape time is displayed for 8 seconds under the following conditions.</p> <ul style="list-style-type: none"> – If the remaining tape time is determined when you turn on power while a cassette is loaded in the unit. – When you press the PLAY button. <p>Always displays under the following conditions.</p> <ul style="list-style-type: none"> – Fast forward, rewind – Fast forward during playback, rewind during playback <p>▶ ON : Always displays the remaining tape time.</p> |



Operating Menus

AUDIO SET menu

| Icon/Menu | Submenu | Setting |
|---|------------------------------|---|
|  AUDIO SET | AUDIO MODE (page 39) | <p>Selects the audio mode.</p> <p>FS32K : Switches the audio mode to 4-channel mode (12-bit mode).</p> <p>▶FS48K : Switches the audio mode to 2-channel mode (16-bit mode). (This setting records the sound in all audio ranges, providing a high-quality sound recording.)</p> <p>Notes</p> <ul style="list-style-type: none"> You can set this menu when recording in DV format only. When signals are input from the , HDV/DV jack, the audio mode of the signals to be recorded is the same as that of the input signals. Recording performs automatically in [FS48K] mode in HDV format. You cannot change the current setting during recording. Noise may occur at the instant you switch the audio mode. To dub audio using an audio dubbing device, select [FS32K]. |
| | AUDIO AGC (page 39) | <p>Selects whether to adjust the [AUDIO REC LV] automatically or not.</p> <p>▶ON : Adjusts the audio recording level automatically.</p> <p>OFF : Adjusts the audio recording level manually. (Set the audio recording level with [AUDIO REC LV] (page 54).)</p> <p>Note</p> <p>Even when this menu is set to [ON], the setting is not effective against a volume level which exceeds the dynamic range of the input amplifier. For details on the available volume levels, see “Specifications” of the unit (page 75).</p> |
| | AUDIO REC LV (page 40) | <p>Adjusts the audio recording level for analog audio input (CH-1 and 2) while recording.</p> <p>-6 dB : Decreases 6 dB from the original audio input level.</p> <p>▶0 dB : Leaves the original audio input level.</p> <p>+6 dB : Increases 6 dB from the original audio input level.</p> <p>Notes</p> <ul style="list-style-type: none"> This setting is available only when [AUDIO AGC] is set to [OFF]. When the level reaches the maximum value of the audio level meter and the meter turns red, the sound will be distorted. For details on the maximum audio recording level input, see “Specifications” of the unit (page 75). |
| | AUDIO MIX (pages 12, 19) | <p>Selects the audio to be output from the AUDIO jacks during the 4-channel mode.</p> <p>▶CH1, CH2 : Outputs only channels 1 and 2 audio.</p> <p>MIX : Outputs the synthesized audio of channels 1 and 3, and channels 2 and 4. (The audio output level becomes 50% (-6 dB) of the original audio levels on each channel.)</p> <p>CH3, CH4 : Outputs only channels 3 and 4 audio.</p> <p>Notes</p> <ul style="list-style-type: none"> You cannot set this menu for a tape recorded using the [FS48K] audio mode of the [AUDIO MODE] menu. You cannot set this menu during HDV recording/playback. The audio level meter displays the audio level of the current setting in this menu. |
| | AUDIO LOCK (pages 39, 71) | <p>▶UNLOCK MODE : Records the sampling clocks of audio and video independently. This mode applies to a consumer DV tape.</p> <p>LOCK MODE : Synchronizes the sampling clocks of the audio and video for recording. This setting is effective for digital processing and performs a clean splice during the audio editing process.</p> <p>Notes</p> <ul style="list-style-type: none"> You can set this menu when recording in DV (SP) format only. When recording in HDV or DVCAM format, the menu is set to [LOCK MODE]. During i.LINK input, the same setting as that of the input signal is selected, regardless of this setting. |

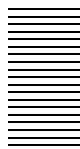

| Icon/Menu | Submenu | Setting |
|-----------|------------------------|--|
| AUDIO SET | JOG AUDIO (page 34) | <p>Selects either to turn the sound output on or off when the tape is played at a speed other than normal. (Available in DVCAM/DV format only.)</p> <p>▶ OFF : Does not output the sound when playing a tape at a speed other than normal.</p> <p>ON : Outputs the sound when playing a tape at a speed other than normal.</p> <p>Notes</p> <ul style="list-style-type: none"> • When a tape recorded in HDV format is played back, the sound cannot be output in various speeds. • Even if you have set this item to ON, the sound may not be output or may be interrupted depending on the recording format or tape conditions. |

VTR SET menu





| Icon/Menu | Submenu | Setting |
|-----------|------------------------------|---|
| VTR SET | AUTO REPEAT (page 35) | <p>Selects whether to playback with automatic repeat or not.</p> <p>▶ OFF : Disables playback with AUTO REPEAT.</p> <p>ON : Enables playback with AUTO REPEAT.</p> |
| | AUTO INDEX (page 40) | <p>Selects whether or not to mark an index signal automatically when the unit in the stop mode starts recording.</p> <p>▶ ON : Marks an index signal at the beginning of the recording.</p> <p>OFF : Does not mark an index signal at the beginning of the recording.</p> |
| | STILL PICT | <p>Selects the image displayed in the still mode (DVCAM/DV (SP) format only).</p> <p>▶ AUTO : Displays an optimized image according to the movement in the image.</p> <p>FRAME : Displays a frame image.</p> <p>FIELD : Displays a field image.</p> <p>Notes</p> <ul style="list-style-type: none"> • If you select [FIELD], the image of field 2 is displayed. • For an HDV format video, an optimized image according to the movement in the image is displayed. |
| | FF/REW SPEED (pages 8, 9) | <p>Selects the tape transport mode in fast-forward and rewind.</p> <p>▶ FF/REW : Fast-forwards or rewinds the tape at maximum speed without displaying the picture.</p> <p>SHUTTLEMAX : Fast-forwards or rewinds the tape at maximum speed while displaying the picture.</p> <p>DVCAM</p> <p>NTSC: Approx. 14 times normal speed</p> <p>PAL: Approx. 17 times normal speed</p> <p>HDV/DV(SP)</p> <p>Approx. 24 times normal speed</p> |
| | STILL TIME | <p>Selects the time to switch to the tape protection mode from the still mode.</p> <p>▶ 30sec : 30 seconds</p> <p>1min : 1 minute</p> <p>2min : 2 minutes</p> <p>3min : 3 minutes</p> <p>Notes</p> <ul style="list-style-type: none"> • If the unit is left in the playback pause mode for a long time, the tape or the video heads may be damaged or the video heads may become clogged. Select the shortest time possible. Particularly, when using a Mini-DV cassette that is longer than 60 minutes, select [30sec] or [1min]. • When the setting is changed in the playback pause mode, the first tape protection mode change uses the time setting from before the settings were changed. From the second tape protection mode change, the new time setting is used. |

(Continued)

Operating Menus

| Icon/Menu | Submenu | Setting |
|---|------------|--|
|  VTR SET | FROM STILL | <p>Selects the tape protection mode to change the mode to after the time set in [STILL TIME] is past.</p> <p>▶STOP : Stops the tape. STEP FORWARD : Forwards one frame.</p> <p>Note If you play a tape recorded in HDV format with [STEP FORWARD] selected, the tape advances a few frames forward at a time.</p> |
| | FROM REC P | <p>Selects the tape protection mode which the unit changes to after the recording has been paused for more than 3 minutes.</p> <p>▶STOP : Stops the tape. REC PAUSE : Maintains the recording pause mode.</p> <p>Note When the recording pause mode continues for a long time after you select [REC PAUSE], the tape may be damaged or the video heads may be damaged or clogged. If there is no other reason to do otherwise, select [STOP]. Particularly when you use a Mini-DV cassette that is longer than 60 minutes, select [STOP].</p> |

TC/UB SET menu

| Icon/Menu | Submenu | Setting |
|---|--------------|---|
|  TC/UB SET | HDV/DV IN TC | <p>Selects whether to record internal time code or external time code while the unit records signals input from the , HDV/DV jack.</p> <p>▶INTERNAL : Records the time code generated by the internal time code generator. (If there is time code already recorded on the tape, the unit records continuous time code from this point.)</p> <p>EXTERNAL : Records the time code with video and audio signals input from the , HDV/DV jack.</p> <p>Notes</p> <ul style="list-style-type: none"> • Bars (---:--:--:--:--:--) are recorded as the time code if you start recording when this item is set to [EXTERNAL], the INPUT SELECT switch on the front panel is set to HDV/DV, and no signal is input via the , HDV/DV jack. When any signals are input, the time code of the signals is recorded. • If you set this item to [EXTERNAL] and the external time code input is discontinuous or does not advance correctly, recording or displaying of the time code on the unit may not be done correctly. If there is a discontinuous time code on your recorded tape, you may not be able to edit or search correctly, depending on the device used to edit. |

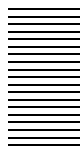

| Icon/Menu | Submenu | Setting |
|-----------------|-----------|--|
| 00:00 TC/UB SET | TC FORMAT | <p>Selects the recording mode of the time code when 60i format is used.</p> <p>▶ AUTO : Automatically sets the mode in accordance with the mode already set on a cassette tape. (If nothing is recorded on the tape, the non-drop frame mode is set. If the unit cannot correctly read the frame mode on the tape, it will use the frame mode that was set in the last position on the tape that the unit can read correctly. If you remove the cassette, the mode of the last position that the unit was able to read correctly is cleared and the non-drop frame mode is set when recording is restarted from the same position. If [TC MAKE] is set to [PRESET], the non-drop frame mode is set.)</p> <p>DF : Selects the drop frame mode.</p> <p>NDF : Selects the non-drop frame mode.</p> <p>Note</p> <p>When [60i/50i SEL] is set to [50i], the unit operates as a 50i specification model. Therefore, the time code is set to the non-drop frame mode. Even if 60i signals are input via an i.LINK connection when [60i/50i SEL] is set to [50i], the time code generated by the unit is in the non-drop frame mode regardless of the [TC FORMAT] setting. To set the time code to the drop frame mode, set [60i/50i SEL] to [60i]. As a result, [TC FORMAT] setting will return to the status before the [60i/50i SEL] menu was set to [50i].</p> |
| | TC RESET | <p>Resets the time code value to 00:00:00:00.</p> <p>▶ NO : Does not reset the time code value.</p> <p>YES : Resets the time code value.</p> <p>Note</p> <p>When This setting is available only when the unit is in REC or REC PAUSE mode. Also, when the INPUT SELECT switch is set to HDV/DV and [HDV/DV IN TC] is set to [EXTERNAL], this setting will not be affected and the time code will not be reset.</p> |

OTHERS menu

| Icon/Menu | Submenu | Setting |
|-----------|------------------------|--|
| OTHERS | LANGUAGE | You can select the desired language on the Data display screen. You can choose Simplified English if your native language is not available among the options. |
| | COMMANDER (page 17) | <p>Selects the control device.</p> <p>▶ WIRELESS : Enables operation by the Remote Commander.</p> <p>CONTROL S : Enables operation by the DSRM-10 remote control unit (not supplied) connected to the CONTROL S jack. (The Remote Commander is disabled.)</p> <p>Notes</p> <ul style="list-style-type: none"> The unit accepts signals from any Sony Remote Commander with its command mode set to VTR4, not only the supplied one. To disable operation from any Remote Commander, set this item to CONTROL S. You can use the DSRM-20 (no longer manufactured: not supplied). |
| | PB YNR | <p>Selects the noise reduction level for the luminance signals when a tape is played.</p> <p>▶ OFF : No noise reduction</p> <p>LOW : Low noise reduction</p> <p>HIGH : High noise reduction</p> <p>Notes</p> <ul style="list-style-type: none"> When you use noise reduction, there may be an afterimage depending on the condition of the picture. Noise reduction is also available with pictures output from the HDV/DV jack. Use caution when dubbing and editing a picture via the HDV/DV jack. |

(Continued)

Operating Menus

| Icon/Menu | Submenu | Setting |
|-----------|--------------------------|--|
| OTHERS | PB CNR | <p>Selects the noise reduction level for the chrominance signals when a tape is played.</p> <p>► OFF : No noise reduction LOW : Low noise reduction HIGH : High noise reduction</p> <p>Notes</p> <ul style="list-style-type: none"> When you use noise reduction, there may be an afterimage depending on the condition of the picture. Noise reduction is also available with pictures output from the HDV/DV jack. Use caution when dubbing and editing a picture via the HDV/DV jack. |
| | CLOCK SET (page 38) | <p>1 Press the buttons to adjust the number, then press the buttons to set the month, day, hour, and minute.</p> <p>2 Press the EXEC button to execute.</p> <p>Notes</p> <ul style="list-style-type: none"> 12:00 AM stands for midnight and 12:00 PM stands for noon when [TIME DISPLAY] in [DISPLAY SET] menu is set to [12H]. If you do not use the unit for 3 months or more, the built-in rechargeable battery will become completely discharged, and the settings of the day and the time may be cleared from the memory. In this case, charge the built-in rechargeable battery and set the clock again (page 70). |
| | HOURS METER (page 70) | <p>Displays the accumulated time counts (using the digital hours meter) in units of 10 hours or 10 counts.</p> <p>OPERATION : Power on duration DRUM RUN : Drum rotation duration TAPE RUN : Tape run duration THREADING : Tape unthreading count</p> |
| | AC ON MODE | <p>Switches the state into which the unit goes when it is connected to the AC outlet.</p> <p>► STANDBY : Makes the unit go into the standby mode. ON : Turns the unit on.</p> |
| | 60i/50i SEL (page 38) | <p>Switches between 1080/60i (NTSC) and 1080/50i (PAL).</p> <p>1 Press the buttons to select [YES], then press the EXEC button.</p> <div style="border: 1px solid black; padding: 5px; margin: 10px auto; width: fit-content;"> <p>60i/50i SEL Change to 50i? Reboots after change.</p> <hr/> <p>YES NO</p> </div> <p>2 Press the buttons to select [YES] again, then press the EXEC button.</p> |
| | INITIALIZE | <p>Resets the settings to the default settings, except the CLOCK SET settings.</p> <p>1 Press the buttons to select [YES], and then press the EXEC button.</p> <div style="border: 1px solid black; padding: 5px; margin: 10px auto; width: fit-content;"> <p>INITIALIZE Reset all settings except "CLOCK SET" to defaults.</p> <hr/> <p>YES NO</p> </div> <p>2 Press the buttons to select [YES] again, then press the EXEC button.</p> |

Maintenance

Troubleshooting

Please check the following before contacting your Sony dealer.

General Operation Troubles



| Symptom | Cause/Remedy |
|---|---|
| A menu item is not available. | <ul style="list-style-type: none"> • There are menus that cannot be used depending in the [IN/OUT REC] menu setting. → Change the [IN/OUT REC] menu settings (<i>page 50</i>). • Some menu items are only available in EE mode or playback mode. → Set the unit to EE mode or playback mode. • Some menu items are only available when the tape is inactive. • There are some menus you cannot use without setting the clock. |
| Some menu item settings change accidentally. | <ul style="list-style-type: none"> • You have pulled out the power cord during a menu operation. → Adjust the menu again. To prevent this incident recurring, do not pull out the plug while adjusting the menu or the brightness of the LCD monitor. |
| The unit operates by itself. | <ul style="list-style-type: none"> • [COMMANDER] in the [OTHERS] menu is set to [WIRELESS] and a Sony Remote Commander with its command mode set to VTR4 is operating near the unit. → Set [COMMANDER] to [CONTROL S] (<i>page 57</i>). |
| The supplied wireless Remote Commander does not work. | <ul style="list-style-type: none"> → Set [COMMANDER] in the [OTHERS] menu to [WIRELESS] (<i>page 57</i>). |
| Even though the settings on the unit are correct, you cannot make the unit record using the DSRM-10 Remote Control Unit (not supplied). | <ul style="list-style-type: none"> → On the DSRM-10 Remote Control Unit, press the PLAY button while holding the REC button down. |
| Whenever you connect the unit to an AC outlet or the AC Adaptor, the unit turns on automatically. | <ul style="list-style-type: none"> • [AC ON MODE] in the [OTHERS] menu is set to [ON]. → Set [AC ON MODE] to [STANDBY] (<i>page 58</i>). • There is a cassette inside the unit and [AUTO REPEAT] in [VTR SET] menu is set to [ON]. → Set [AUTO REPEAT] to [OFF] (<i>page 55</i>). |

Troubleshooting

Power sources

| Symptom | Cause/Remedy |
|---|--|
| The power cannot be turned on. | <ul style="list-style-type: none"> The AC power cord is disconnected. → Connect the AC power cord. |
| The unit will not operate even if the power has been turned on. | <ul style="list-style-type: none"> Moisture condensation has occurred (<i>page 69</i>). The cassette is not inserted straight. → Eject and reinsert it correctly. → Disconnect the power supply and then reconnect it after about 1 minute. If the unit does not operate even after you reconnect the power, use a sharp-tipped ballpoint pen or similar tool to press the RESET button. When you press the RESET button, all settings, including the date, time, and 60i/50i are initialized (<i>page 13</i>). |
| The unit does not operate properly when the AC Adaptor is used. | → Turn off the power and remove the power cord from the AC outlet and then reconnect the power cord. |



Cassette tapes

| Symptom | Cause/Remedy |
|--|---|
| The cassette cannot be inserted. | <ul style="list-style-type: none"> There is moisture condensation on the head drum (<i>page 69</i>). → With the unit powered on, wait more than one hour. The cassette is not inserted straight. → Eject and reinsert it correctly. Another cassette has been loaded already. → Remove the cassette and insert the one you want to load. |
| It takes time to eject the cassette. | <ul style="list-style-type: none"> This is not a malfunction. → The unit ejects the cassette slowly to protect the tape. While the cassette is being ejected, the  (cassette) indicator blinks. |
| The cassette tape is not ejected when you press the EJECT button. | <ul style="list-style-type: none"> → Check whether the power supply is connected properly. Moisture condensation has occurred in the unit (<i>page 69</i>). |
| The cassette memory data and title are not displayed when using a cassette tape with the cassette memory function. | <ul style="list-style-type: none"> The unit does not support the cassette memory function and therefore such data is not displayed. |
| The remaining tape time is not displayed. | → To always display the remaining tape time, set [ REMAINING] in the [DISPLAY SET] menu to [ON] (<i>page 53</i>). |

Output/Playback

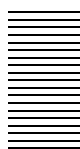
| Symptom | Cause/Remedy |
|--|---|
| Superimposed text data is displayed on the monitor. | → Change the setting of the DISPLAY OUTPUT switch on the front panel (<i>page 6</i>). You cannot select the type of the text data to be displayed. |
| Cannot playback. | → If the tape has reached its end, rewind the tape. |
| Cannot playback in reverse at various speeds. | <ul style="list-style-type: none"> The unit cannot play back a tape recorded in HDV format in the reverse direction at various speeds (<i>page 33</i>). |
| 30p and/or 24p characteristics of the tape are not detected. | <ul style="list-style-type: none"> While the tape is fast forwarding or rewinding during playback, a portion of the tape recorded using 30p or 24p system has been detected as that of a 60i system. → To detect the portion as 30p or 24p, search for the part during playback at normal speed. |



| Symptom | Cause/Remedy |
|---|---|
| Horizontal lines are displayed on an image. An image has block noise. An image is blurred or not displayed. | <ul style="list-style-type: none"> • The video heads are dirty. → Clean the video heads using the supplied cleaning cassette. • A damaged tape is loaded. → Remove the cassette and insert another one. • You have tried to make the unit play back a tape recorded in LP mode of the DV format. → The unit can play back only tapes recorded in the HDV, DVCAM format or in SP mode of the DV format. A tape recorded in LP mode of the DV format cannot be played back on the unit (page 23). |
| A picture input via the  HDV/DV jack is not displayed. | <ul style="list-style-type: none"> → Reconnect the i.LINK cable (not supplied). • The INPUT SELECT switch is set to a position other than HDV/DV. → Set the switch to HDV/DV (page 6). → Set [HDV/DV SEL] in the [IN/OUT REC] menu correctly (page 50). |
| EE picture and EE sound are not output. | <ul style="list-style-type: none"> • [EE/PB SEL] in the [IN/OUT REC] menu is set to [PB]. → Set [EE/PB SEL] to [EE] (page 52). • The setting of the INPUT SELECT switch does not match the signal input. → Set the switch according to the signal input (page 6). |
| The audio breaks up. | <ul style="list-style-type: none"> • A damaged tape is loaded. → Remove the cassette and insert another one. • The video heads are dirty. → Clean the video heads using the supplied cleaning cassette. • You have tried to make the unit play back a tape recorded in LP mode of the DV format. → The unit can play back only tapes recorded in the HDV, DVCAM or DV (SP) formats. A tape recorded in LP mode of the DV format cannot be played back on the unit (page 23). |
| Cannot perform a date search or index search. | <ul style="list-style-type: none"> • There is a portion with no recording at the beginning or in the middle of a tape. This is not a malfunction. |
| The time code is not reset to “00:00:00:00” after rewinding a tape to the recording starting point. | <ul style="list-style-type: none"> • The time code is not displayed correctly at the starting point of recording. This condition, however, is not a malfunction. When you restart playback, the time code and images are displayed correctly from the starting point. |
| “— — — —” appears on the date display (page 32). | <ul style="list-style-type: none"> • The tape has been played back without setting the date and time. → Set the date and time (page 58). • The tape portion being played back has no recording. • If there is a scratch or noise on the tape, the data code cannot be read. |
| Although the component video cable is connected properly to a television set or monitor to play back a tape, no image or audio is output. | <ul style="list-style-type: none"> → Use the correct setting for [COMPONENT] of [VIDEO OUT] in the [IN/OUT REC] menu depending on the equipment connected (page 27, 51). • No audio is output from the COMPONENT OUT jacks. → Connect an audio cable. |
| When you connect the unit to a 4:3 television set, the displayed image appears flattened. | <ul style="list-style-type: none"> → When you output from the COMPONENT OUT jacks, set [COMPONENT] and [DOWN CONVERT] of [VIDEO OUT] in the [IN/OUT REC] menu correctly before playback (page 27, 51). When you output from the  HDV/DV jack, set [HDV → DV CONV] and [DOWN CONVERT] of [i.LINK SET] in the [IN/OUT REC] menu correctly before playback (page 28, 51). When you output from the S VIDEO jack and VIDEO jack, set [DOWN CONVERT] of [VIDEO OUT] in the [IN/OUT REC] menu correctly before playback. → DVCAM/DV tape images recorded in the wide mode are not displayed properly. Use a widescreen-compatible monitor. |

(Continued)

Troubleshooting

| Symptom | Cause/Remedy |
|--|---|
| Even though [HDV/DV IN TC] in the [TC/UB SET] menu is set to [EXTERNAL], the time code of the input i.LINK signal is not recorded. | <ul style="list-style-type: none"> The i.LINK signal output from the digital non-linear editing controller does not include a time code. → Confirm that the editing software you are using is capable of outputting a time code. The INPUT SELECT switch is not set to HDV/DV. → Set it to HDV/DV (page 6). |
| After playing at 1/10 of normal speed in forward or reverse for more than 1 minute, normal playback forward starts. | <ul style="list-style-type: none"> To protect a tape, the unit is set to start normal playback after playing at 1/10 of normal speed in forward or reverse for more than 1 minute. → Play back the tape at 1/3 of normal speed in forward or reverse. |
| Playback pause mode is released and the unit goes into the stop mode. | <ul style="list-style-type: none"> To protect the tape, the unit is set to go into the stop mode after the playback pause mode continues for a certain period. → Set [FROM STILL] in the [VTR SET] menu to [STEP FORWARD]. If you do so, the tape will forward by one frame for each time interval set in [STILL TIME] (page 56). |
| Playback pause mode is released and the tape forwards for each preset time interval. | <ul style="list-style-type: none"> To protect the tape, the unit is set to forward the tape after the playback pause mode continues for a certain period. → Set [FROM STILL] in the [VTR SET] menu to [STOP]. If you do so, the unit goes into the stop mode after the playback pause mode continues for the interval set in [STILL TIME] (page 56). |
| The pause mode of recording is released automatically. | <ul style="list-style-type: none"> To protect the tape and the video heads, the unit goes into the stop mode after the pause mode of recording, audio dubbing, or duplicating continues for more than 3 minutes. → To maintain the pause mode, set [FROM REC P] in the [VTR SET] menu to [REC PAUSE] (page 56). |
| When the tape is rewound to its beginning, the playback automatically starts. | <ul style="list-style-type: none"> [AUTO REPEAT] in the [VTR SET] menu is set to [ON]. → Set [AUTO REPEAT] to [OFF]. You pressed the PLAY button while holding the REW button down. → If you do this, the unit rewinds the tape to its beginning and begins playback (page 9). |
| During playback, the unit starts rewinding suddenly. | <ul style="list-style-type: none"> [AUTO REPEAT] in the [VTR SET] menu is set to [ON]. → When [AUTO REPEAT] is set to [ON], the unit starts rewinding at the moment when a signal for index search or a blank portion is detected. Set [AUTO REPEAT] to [OFF]. |
| When the tape reaches its end, rewinding starts automatically. | <ul style="list-style-type: none"> [AUTO REPEAT] in the [VTR SET] menu is set to [ON]. → When [AUTO REPEAT] is set to [ON], the unit starts rewinding at the moment when the end of the tape is detected. Set [AUTO REPEAT] to [OFF]. |
| No sound or undesired sound is output from the AUDIO OUT jacks. | <ul style="list-style-type: none"> → When the audio mode is 32 kHz (4-channel), you can select the audio channel. Set [AUDIO MIX] in the [AUDIO SET] menu according to the desired channel. |
| The unit starts playback itself without commands. | <ul style="list-style-type: none"> [AUTO REPEAT] in the [VTR SET] menu is set to [ON]. → Set [AUTO REPEAT] to [OFF]. When [COMMANDER] in the [OTHERS] menu is set to [WIRELESS], the unit responds to signals from the Remote Commander. → Set [COMMANDER] to [CONTROL S]. |
| The unit does not function as part of a digital non-linear editing system. | <ul style="list-style-type: none"> The INPUT SELECT switch is set to a setting other than HDV/DV. → Set it to HDV/DV (page 6). The editing controller or the editing software is not compatible with the unit. → Refer to the instruction manuals of the controller or the software and consult their manufacturers. |
| Although the i.LINK cable is connected, the image from external equipment is not displayed. | <ul style="list-style-type: none"> → Disconnect and then reconnect the i.LINK cable correctly. The INPUT SELECT switch is set to a setting other than HDV/DV. → Set it to HDV/DV (page 6). |

| Symptom | Cause/Remedy |
|---|---|
| No image is displayed even though the video cable is connected correctly. | <ul style="list-style-type: none"> • There are output restrictions for some [COMPONENT] settings of [VIDEO OUT] in the [IN/OUT REC] menu. For details, <i>see page 51</i>. • The INPUT SELECT switch setting does not match the cable connected to the unit. <ul style="list-style-type: none"> → Set the INPUT SELECT switch to S VIDEO or VIDEO to match the cable connection. |
| The image loses color or is distorted when you play back the tape on a television set or monitor connected to the unit. | <ul style="list-style-type: none"> → Connect the unit to a television set or monitor that is compatible with its [60i/50i SEL] format. → Set [60i/50i SEL] in the [OTHERS] menu, according to the signal-format (<i>page 58</i>). |
| 2/2-ST is displayed on the screen. | <ul style="list-style-type: none"> • This icon is displayed when you playback a tape recorded with 4-channel microphone recording on another device using external surround microphones. The unit does not support 4-channel microphone recording using external surround microphones. (This icon is displayed when you play back a tape recorded with external 4-channel recording using a surround microphone in DVCAM or DV (SP) format.) |

Recording

| Symptom | Cause/Remedy |
|---|---|
| No picture is output via the  HDV/DV jack. | <ul style="list-style-type: none"> → Reconnect the i.LINK cable (not supplied). • INPUT SELECT switch is set to a position other than HDV/DV. <ul style="list-style-type: none"> → Set the switch to HDV/DV (<i>page 6</i>). → Set [HDV/DV SEL] in the [IN/OUT REC] menu correctly (<i>page 50</i>). |
| You do not know how to adjust the input level. The recorded level is too low. The recorded sound is distorted. | <p>Confirm the level of the sound output from the player by referring to the player's instruction manual.</p> <p>If you are not clear about the player's output level, try the following procedures.</p> <ul style="list-style-type: none"> • Set [AUDIO AGC] in the [AUDIO SET] menu to [OFF], set [AUDIO REC LV] to [0 dB], and play back the tape which you intend to use for playback to check the audio level meter. If the audio level meter lights up in red at the maximum audio level of the playback, set [AUDIO REC LV] to [-6 dB]. When the volume is too low, set [AUDIO REC LV] to [+6 dB]. If the audio level meter lights up in red, the sound will be distorted. For details of the acceptable maximum input level, <i>see page 75</i>. |
| No sound or undesired sound is output from the AUDIO OUT jacks. | <ul style="list-style-type: none"> • When the audio mode is 32 kHz (4-channel), set [AUDIO MIX] in the [AUDIO SET] menu to [CH1, CH2]. When the audio mode is 32 kHz (4-channel), audio is recorded in channel 1/2 on the unit. |
| If an i.LINK cable is connected when you edit the dubbing, the monitor does not display any image. | <ul style="list-style-type: none"> → Use the correct setting for [HDV/DV SEL] in the [IN/OUT REC] menu in accordance with the equipment to be connected (<i>page 50</i>). |
| EE sound is not output. | <ul style="list-style-type: none"> • When the audio mode is 32 kHz (4-channel), set [AUDIO MIX] in the [AUDIO SET] menu to [CH1, CH2] or [MIX]. |
| EE picture and EE sound are not output. | <ul style="list-style-type: none"> • [EE/PB SEL] in the [IN/OUT REC] menu is set to [PB]. <ul style="list-style-type: none"> → Set [EE/PB SEL] to [EE]. • The setting of the INPUT SELECT switch does not match the signal input. <ul style="list-style-type: none"> → Set the switch according to the signal input. • With an analog connection, the current setting of [60i/50i SEL] in the [OTHERS] menu is not appropriate. <ul style="list-style-type: none"> → Set it to the appropriate position for the device you are using. |

(Continued)

Troubleshooting

| Symptom | Cause/Remedy |
|--|--|
| The unit does not function as part of a digital non-linear editing system. The functions on the unit do not operate. | <ul style="list-style-type: none">• The INPUT SELECT switch is set to a setting other than HDV/DV. → Set it to HDV/DV (<i>page 6</i>).• The editing controller or the editing software is not compatible with the unit. → Refer to the instruction manuals of the controller or the software and consult their manufacturers. |



Warning Indicators and Messages

Self-diagnosis display/Warning Indicators

The following alarm indicators may appear on the LCD monitor or an external monitor. For further information about each symptom and recovery method, see the relevant page indicated in the parentheses.











| Message/Alarm Indicator | Cause/Corrective Action |
|--|---|
| C:□□:□□/E:□□:□□ (Self-diagnosis display) | <p>If an error still recurs after you retry the corrective action several times, contact Sony Customer Service or your place of purchase.</p> <p>C:21:□□ → Condensation has occurred. Remove the cassette and insert it again after approximately 1 hour (<i>page 69</i>).</p> <p>C:22:□□ → The video head is dirty. Use a cleaning cassette to clean the head (<i>page 67</i>).</p> <p>C:31:□□/C:32:□□ → Symptoms other than the above are occurring. Insert the cassette again and retry the operation. Do not take this action, however, if there is any condensation at all in the unit (<i>page 69</i>). → Unplug the power cord, plug it in again, and then retry the operation. → Replace the tape.</p> |
| ☒ (Moisture condensation warning)* | → Remove the cassette, unplug the power cord, and leave the unit for approximately 1 hour (<i>page 69</i>). |
| 📼 (Warning indicator pertaining to the tape) | <p>The icon blinks slowly.</p> <ul style="list-style-type: none"> The remaining tape time is less than 5 minutes. |
| ▲ (Eject cassette warning)* | <p>The icon blinks rapidly.</p> <ul style="list-style-type: none"> Condensation has occurred (<i>page 69</i>). The self-diagnostics message is displayed (<i>page 65</i>). |

* CAUTION indicator will blink when an alarm indicator or message is displayed (*page 7*).

Warning Indicators and Messages

Alarm Messages

The following alarm messages will appear together with the alarm indicators. Take corrective action according to the displayed message.

| Item | Message | Cause/Corrective Action |
|-----------------------|--|--|
| Moisture condensation |   Moisture condensation. Eject the cassette. | → See page 69 for details. |
| |  Moisture condensation. Turn off for 1H. | → See page 69 for details. |
| Cassette/Tape |  Insert a cassette. | → See page 21. |
| |  Reinsert the cassette. | Check for damage to the tape or other irregularities. |
| |   The tape is locked –check the tab. | → See page 20. |
| |  The tape has reached the end. | — |
| Others | Cannot record due to copyright protection. | — |
| | Change to correct tape format. | This is an unsupported format and cannot be played back. |
| | No output image in “HDV/DV SEL”. Change format. | Stop playback or signal input, or change the [HDV/DV SEL] setting (page 50). |
| |   Dirty video head. Use a cleaning cassette. | → See page 67. |
| | Unplug power cable. | — |
| | Reinsert the cassette. | — |
| | Invalid input signal. | The signal that has been input to the unit is invalid. Check the input signal. |
| | Power voltage error. | — |

Notes on the Videocassette Recorder

Do not use the unit in a place subject to direct sunlight or heat sources

If you do, its cabinet, mechanical parts, etc., may be damaged.

Do not place the unit in humid places

Do not place the unit in places where they may be exposed to water-splash or to humidity. Do not place water-filled containers or vases on the unit. Doing so may cause the unit to malfunction.

Do not use the unit in an extremely hot place

If the unit is left in a car parked with the windows closed (especially in summer), its cabinet, mechanical parts, etc., may be damaged or it may not work correctly.

If the unit is brought directly from a cold to a warm location

Moisture may condense inside the unit and cause damage to the video heads and tape. If you use the unit in a place subject to direct cold currents from an air conditioner, moisture may also condense inside the unit.

Do not place a heavy object on the unit

The cabinet, mechanical parts, etc., may be damaged, or the unit may not work correctly.

Do not handle the unit roughly

Avoid rough handling or mechanical shock to the unit.

To avoid damaging the cabinet's finish

Plastic is often used for the surface finishing of the unit. Do not spray a volatile solvent such as an insecticide toward the cabinet or place rubber or vinyl products on the cabinet for a long time. If you do, the finish of the cabinet may be damaged or the coating may come off.

Do not clean the cabinet with thinner or benzine

The cabinet may be damaged or its coating may come off. When you use a chemical-impregnated cloth, use it according to its directions.

Clean the cabinet with a soft dry cloth

When the cabinet is very dirty, clean it with a soft dry cloth lightly moistened with a mild detergent solution and finish it with a dry cloth.

Do not put magnetic objects close to the unit

Magnetic fields may damage the recording.

To prevent electromagnetic interference caused by radio communication equipment such as cellular phones, transceivers, etc.

The use of radio communication equipment such as cellular phones or transceivers near the unit may cause a malfunction and can affect the audio/video signals. Cellular phones or transceivers near the unit should be switched off.

Do not use the unit in an area exposed to radiation

A malfunction may occur.

Checking the video heads every 1000 hours

A VCR is a high-precision piece of equipment that records and plays back the picture recorded on a magnetic tape. In particular, the video heads and other mechanical parts may become dirty or worn. To maintain a clean picture, we recommend maintenance every 1000 hours, even though the conditions of use may differ, depending on temperature, humidity, dust, etc.

Connecting other equipment

When you connect the unit to other equipment or a computer using an i.LINK cable, confirm the direction of the jack. If you forcibly insert the jack, the terminal may be damaged or cause the unit to malfunction.

Cleaning of the Video Heads

With clogged video heads, the unit cannot record properly. Clean the video heads to prevent noise on the recorded picture or audio. For cleaning, use the supplied cleaning cassette.

Before recording an important event

The unit cannot record properly with clogged video heads. To ensure normal recording and clear pictures and sound, clean the video heads before recording an important event.

Every 50 hours

If you repeat the tape transport operation, the video heads will become dirty and coated with fine dirt or dust. Clean the heads every 50 hours.

After using a tape prone to clog the heads

If using such a tape causes the symptoms illustrated below, clean the heads.

Notes on Use

When the symptoms caused by clogged video heads appear

Even if you clean the heads periodically, clogging of the heads may occur anyway. Clean the heads when:

- mosaic-pattern noise appears on the playback picture.
- the playback picture freezes.
- a part of the playback picture does not move.
- playback pictures do not appear.
- playback audio is interrupted.
- “ Dirty video head. Use a cleaning cassette.” appears during recording.

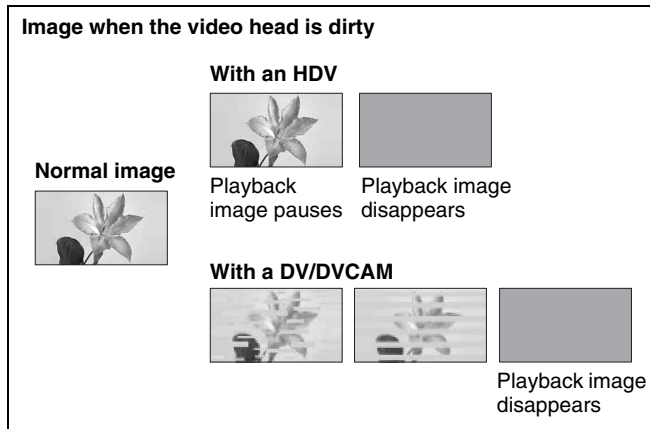

To use the cleaning cassette

Clean the video head by playing the cleaning cassette for ten seconds.

*If the playback image continues to be stationary or any of the symptoms above remain even after cleaning with the cleaning cassette, there may be a problem with the tape. Avoid using that tape.

For details, refer to your cleaning cassette's instruction manual.

Note

Using the unit as listed below will make the video head dirty.

- Subjecting the unit to temperature change or high humidity.
 - Condensation occurs. *See page 69.*
- Using a damaged tape.
- Using the unit for a long time.
- Using the unit where there is a lot of dirt, dust, or sand.
- Leaving a tape in the unit for a long time.

Cleaning cassettes are replaceable. After using the supplied cleaning cassette for the specified number of times, buy a replacement cleaning cassette.

After prolonged use, the video heads may become worn out. If optimum picture quality is not restored even after you have cleaned the video heads with the cleaning cassette, the video heads may have worn out. In that case, you have to replace the video heads with new ones. Please consult your Sony dealer.

Notes on the Video Cassettes

Note that using a tape such as those below can damage the unit.

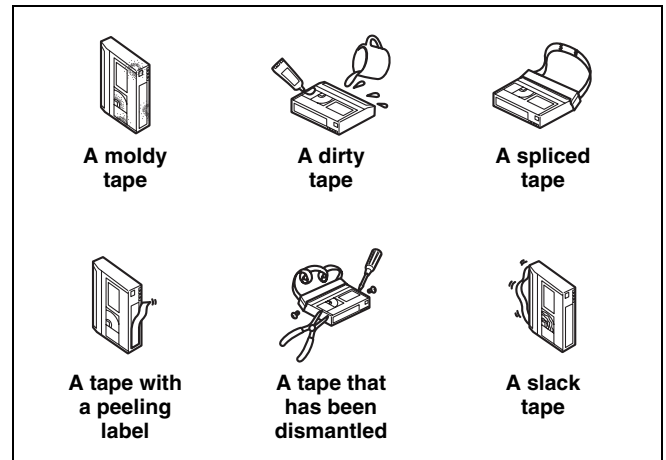

Using cassettes

- When using a cassette for the first time we recommend that you run the tape for about five seconds before recording.
- When using a cassette that has been stored for a long time we recommend that you fast-forward and rewind it for some time. This will correct any winding irregularity in the cassette.
- Do not repeatedly insert and remove a cassette without running it. The tape may become slacked or damaged.

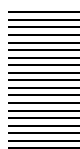

Cleaning the terminal

If the gold-plated terminals of a cassette become dirty, or dirt accumulates on the terminals, the correct remaining tape time may not be displayed.

Clean the terminal with a swab once every ten times you eject that cassette.

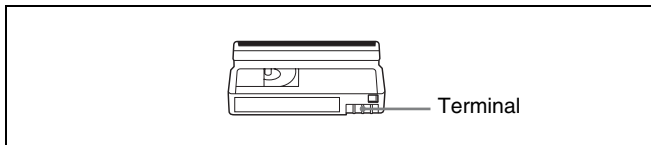

When affixing a label to the cassette

Be sure to affix a label only on the correct location so as not to cause malfunction of the unit.

Storing cassettes

- After using the tapes rewind it, put it in its case and store it vertically. (To prevent picture and sound distortion.)
- Do not store tapes in the following places:
 - Where the temperature gets high (in strong sunshine, inside a car or near a heater)
 - Where there is high humidity
 - In a strong magnetic field (near a TV or speakers)

About Moisture Condensation

If the unit or cassette is brought directly from a cold to a warm location, moisture may condense inside or outside the unit or tape. If you use the tape or video heads in this condition, the tape may adhere to the head drum, and the video heads or the tape may be damaged, or a malfunction may occur. When condensation occurs, the alarm messages “ Moisture condensation. Eject the cassette.” or “ Moisture condensation. Turn off for 1H.” appears. Moisture condensation is likely to occur under the following conditions:

- The unit or cassette is brought from the cold outdoors to a warm indoor location.
- The unit or cassette is brought from the air-conditioned indoors to the hot outdoors.
- The unit is used in a place subject to cold currents from an air conditioner.

When bringing the unit or cassette from a cold place to a warm place or vice versa, put it in a plastic bag and seal the bag tightly. After bringing it into the new place, leave the bag on for more than one hour, and remove the bag when the air temperature inside it has reached the temperature surrounding it.

If moisture condensation occurs

Remove the cassette immediately. While the alarm indicator is displayed, you cannot operate the unit except to press the EJECT button. Turn off the power until the condensation disappears (approximately 1 hour). If the alarm message does not appear when you turn on the unit, and if or does not blink when you insert a cassette and press the video operation button, you can use the unit again. If there is negligible condensation in the unit, this condensation may not be detected. In that case, the cassette may not be ejected for approximately 10 seconds. This is not a malfunction.

Digital Hours Meter

The digital hours meter keeps cumulative counts of the total operation time, the head drum rotation time, the tape running time and the number of unthreading operations. These counts can be displayed on the menu. Use them as guidelines for scheduling maintenance. In general, consult your Sony dealer about necessary periodic maintenance checks.

The digital hours meter has the following four display modes and you can check them in [HOURS METER] of the [OTHERS] menu (page 58).

• OPERATION mode

The cumulative total hours of operating time is displayed in 10-hour increments.

• DRUM RUN mode

The cumulative total hours of drum rotation with tape threaded is displayed in 10-hour increments.

• TAPE RUN mode

The cumulative total hours of tape running time is displayed in 10-hour increments.

• THREADING mode

The cumulative number of tape unthreading operations is displayed in 10-operation increments.

About the Built-in Rechargeable Battery

The unit is provided with a rechargeable battery that retains the date/time and various settings regardless of power-on and power-off status. The rechargeable battery is charged as long as the unit is operated. If the period the unit is operated is short, the battery discharges gradually and if it is not used at all for approximately 1 month, the battery will discharge completely. In that case, charge the battery and then start using the unit. If you do not need to record the date and time when the rechargeable battery is not fully charged, you can use the unit in this state.

Charging the rechargeable battery

Connect the unit to the AC outlet using the AC Adaptor and power cord for about 24 hours. (The unit does not need to be turned on.)

Using your Videocassette Recorder abroad

You can use your Videocassette Recorder in any country/region using the AC Adaptor. Supplied within 100 V to 240 V AC, 50 Hz/60 Hz. Use a commercially available AC plug adaptor [a], if necessary, depending on the design of the wall outlet [b].

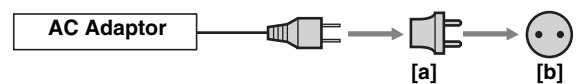

Notes on the License

ANY USE OF THIS PRODUCT OTHER THAN CONSUMER PERSONAL USE IN ANY MANNER THAT COMPLIES WITH THE MPEG-2 STANDARD FOR ENCODING VIDEO INFORMATION FOR PACKAGED MEDIA IS EXPRESSLY PROHIBITED WITHOUT A LICENSE UNDER APPLICABLE PATENTS IN THE MPEG-2 PATENT PORTFOLIO, WHICH LICENSE IS AVAILABLE FROM MPEG LA, L.L.C., 250 STEELE STREET, SUITE 300, DENVER, COLORADO 80206.

Appendix

Notes on Dubbing

Dubbing with the S VIDEO or VIDEO jacks

When you use the unit as a recorder to perform dubbing between the unit and other equipment using the S VIDEO jack and the VIDEO jack, the format to be used for recording is set according to the [ REC MODE] setting in the [IN/OUT REC] menu.

For details, see the following table.

Playback and editing of a tape may be restricted for some dubbing methods. Read Chapter 3 “*Dubbing/Editing*” before dubbing a tape.

Some editing software can correctly edit even a tape created in [LOCK MODE]. In that case, select [LOCK MODE] if required.

Recording tapes used when the unit serves as a recorder

| Input signal format | Menu item | | Recording tape format (AUDIO MODE) |
|---------------------|--|-------------|------------------------------------|
| |  REC MODE | AUDIO LOCK | |
| NTSC or PAL | DVCAM | — | DVCAM (LOCK MODE) |
| | DV SP | LOCK MODE | DV (LOCK MODE) |
| | | UNLOCK MODE | DV (UNLOCK MODE) |

—: Setting independent

Notes on Dubbing

Dubbing with the i HDV/DV jack

When you perform dubbing between the unit and digital video equipment connected with an i.LINK cable using the unit as a player, the i HDV/DV jack output format is determined in accordance with the playback tape format and menu setting of the unit.

If you use the unit as a recorder, the format of a tape used for recording is determined in accordance with the i HDV/DV jack input format and menu setting of the unit. For details, check the following table on *page 73*.

Playback and editing using this tape may be limited for some dubbing methods. Before dubbing, read Chapter 3 “Dubbing/Editing.”

i.LINK output when the unit is used as a player

| Playback tape format | Menu item | | i.LINK output format (AUDIO MODE) |
|----------------------|------------|---------------|-------------------------------------|
| | HDV/DV SEL | i.LINK SET | |
| | | HDV → DV CONV | |
| HDV | AUTO | OFF | HDV (LOCK MODE) |
| | | DVCAM | DVCAM (LOCK MODE) |
| | | DV (SP) | DV (UNLOCK MODE) |
| | HDV | OFF | HDV (LOCK MODE) |
| | | DVCAM | DVCAM (LOCK MODE) |
| | | DV (SP) | DV (UNLOCK MODE) |
| DV | — | No output | |
| DVCAM | AUTO | — | DVCAM (Complies with playback tape) |
| | HDV | — | No output |
| | DV | — | DVCAM (Complies with playback tape) |
| DV | AUTO | — | DV (Complies with playback tape) |
| | HDV | — | No output |
| | DV | — | DV (Complies with playback tape) |

Notes

- When you play back a tape employing a copy-protection signal on the unit, you cannot record images from the unit to other equipment.
- You cannot up convert DVCAM(DV) format to HDV format on the unit.
- During playback in HDV, if [DV SP] is selected from [HDV → DV CONV] in [i.LINK SET], AUDIO MODE is fixed to UNLOCK MODE.
- When you play back a tape in DVCAM or DV format, the unit cannot convert between DVCAM and DV format, or switch between LOCK MODE and UNLOCK MODE.

Recording tape when the unit is used as a recorder

| i.LINK input format | Menu item | | Recording tape format (AUDIO MODE) ³⁾ |
|---------------------|------------|--|---|
| | HDV/DV SEL | [] REC MODE ¹⁾ | |
| HDV | AUTO | — | HDV (LOCK MODE) |
| | HDV | — | HDV (LOCK MODE) |
| | DV | — | No recording |
| DVCAM | AUTO | DVCAM | DVCAM (Complies with input signals) |
| | | DV SP | DV (Complies with input signals) |
| | HDV | — | No recording |
| | DV | DVCAM | DVCAM (Complies with input signals) |
| | | DV SP | DV (Complies with input signals) |
| | DV | AUTO | DVCAM |
| DV SP | | | DV (Complies with input signals) |
| HDV | | — | No recording |
| DV | | DVCAM | DVCAM ²⁾ (Complies with input signals) |
| | | DV SP | DV (Complies with input signals) |

- 1) When the unit is used as a recorder, the recording format is determined by the [] REC MODE] setting in the [IN/OUT REC] menu if the input signal format is DVCAM or DV.
- 2) If you duplicate a tape when the unit is set to DVCAM to be used as a recorder, the time code format of the duplicated tape will be partially different from the time code format specified as DVCAM (note, however, this does not affect editing accuracy in special cases).
- 3) The unit cannot switch between LOCK MODE and UNLOCK MODE. AUDIO MODE complies with input signals.

Notes

- On the unit, HDV signals input from an i.LINK connection cannot be down converted to DVCAM(DV) for recording.
- If you use the tapes described in 2) above for editing, you may encounter function limitations regardless of the player and recorder formats.
- Some DV video equipment may play back a DVCAM-formatted tape, however the contents cannot be guaranteed. Therefore, even though you use a proper DVCAM-formatted tape for playback, and the unit dubs and creates a DVCAM-formatted tape, the time code may be partially different from the time code format specified as DVCAM on other DV video equipment.
- You cannot use the unit to record video and audio recorded with copyright protection signals. If you try to record such video or audio materials, the message “Cannot record due to copyright protection.” appears on the LCD monitor.
- When the video signals input from the  HDV/DV jack in HDV format are recorded, the user bit value is copied to the work tape. (The unit is not equipped with user bit settings and a user bitfs display function.)

About i.LINK

The  HDV/DV jack provided on the unit is an i.LINK-compliant jack. This section describes the i.LINK standard and its features.

What is i.LINK?

i.LINK is a digital serial interface for sending and receiving digital video, digital audio, and other data between the unit and other equipment equipped with an i.LINK terminal. You can also control other equipment using i.LINK. i.LINK-compatible equipment can be connected using an i.LINK cable. Possible applications are operations and data exchange with various digital AV equipment. When two or more i.LINK-compatible pieces of equipment are connected to the unit, operations and data exchange are possible with equipment directly connected to the unit and also with equipment connected to the unit via other equipment. Note, however, that the method of operation may vary depending on the characteristics and specifications of the equipment to be connected. Also, there are cases where operations and data exchange may not be possible even if the connection is made.

Notes

- Normally, only one device can be connected to the unit using an i.LINK cable. When you connect the unit to HDV/DVCAM (DV)-compliant equipment that allows multiple connections, refer to the operating instructions of the equipment to be connected.
- i.LINK is an easy-to-remember term for the IEEE 1394 standard proposed by Sony, and is a trademark approved by many corporations in Japan and overseas.
- IEEE 1394 is an international standard standardized by the Institute of Electrical and Electronics Engineers.

About the i.LINK baud rate

The maximum baud rate of i.LINK varies depending on the equipment. There are three types.

S100 (Approximately 100 Mbps*)

S200 (Approximately 200 Mbps)

S400 (Approximately 400 Mbps)

The baud rate is listed under “Specifications” in the operating instructions of individual equipment. It may be indicated near the i.LINK interface on some equipment.

The baud rate may vary from the indicated value when the unit is connected to equipment with a different maximum baud rate.

*What is Mbps?

Mbps stands for “megabits per second,” or the volume of data that can be sent or received in 1 second. For example,

a baud rate of 100 Mbps means that 100 megabits of data can be sent in 1 second.

To use the i.LINK functions of the unit

For details on how to perform dubbing when the unit is connected to other video equipment that has an i.LINK jack, *see page 37, 41*. The unit can also be connected to other i.LINK-compatible equipment made by Sony (i.e., a VAIO series computer) as well as video equipment. The unit may not be able to operate with some i.LINK video equipment such as digital televisions, DVD recorders/players, and MICROMV recorders/players even if they are equipped with an i.LINK jack. Before connecting to another equipment, confirm whether this equipment is HDV/DVCAM (DV) compatible. For details on precautions on connections and whether or not software applications compatible with the unit are available, refer to the operating instructions of the equipment to be connected.

Notes

- When you connect a computer and the unit using an i.LINK cable, check the direction of the jack. If you forcibly insert the jack, the terminal may be damaged or cause the unit to malfunction.
- Be sure to connect the i.LINK cable to the computer first and then connect it to the unit. If you connect the i.LINK cable to the unit first, it may cause the unit to malfunction because of static electricity.
- When you connect the unit to equipment equipped with an i.LINK jack using the i.LINK cable, power off the equipment and remove the power cord from the AC outlet before connecting (or disconnecting) the i.LINK cable. If the i.LINK cable is connected (or disconnected) while the equipment power cord is connected to the AC outlet, a high-voltage current (8 to 40 V) output from the i.LINK jack of the equipment flows into the unit and may damage it.
- However the  HDV/DV jack of the unit is a 6-pin type, so no power is supplied.

Recommended i.LINK cables

Use a Sony i.LINK cable.

i.LINK and  are trademarks of Sony Corporation.

Specifications

System

| | |
|---|--|
| Video/Audio recording/playing head system | Rotating dual-head helical scan |
| Audio recording format (HDV) | MPEG-1 Audio Layer2 (2-channel) 16-bit 48 kHz (stereo) Transfer rate 384 kbps |
| Audio recording format (DVCAM (DV)) | 12-bit Fs32K (Channel 1/2, Channel 3/4) 16-bit Fs48K (Channel 1/2) |
| Video signal | 1080/60i, NTSC color, EIA standard system 1080/50i, PAL color, CCIR standard system |
| Usable cassettes | Standard DVCAM cassettes with the DVCAM ™ mark Mini DVCAM cassettes with the DVCAM ™ mark |
| Tape speed (HDV) | Approx. 18.8 mm/s |
| Tape speed (DVCAM) | Approx. 28.2 mm/s |
| Tape speed (DV) | SP: Approx. 18.8 mm/s |
| Recording/playback time (HDV) | Approx. 276 min (using PHDV-276DM) Approx. 63 min (using PHDVM-63DM) |
| Recording/playback time (DVCAM) | Approx. 184 min (using PHDV-276DM) Approx. 41 min (using PHDVM-63DM) |
| Recording/playback time (DV SP) | Approx. 276 min (using PHDV-276DM) Approx. 63 min (using PHDVM-63DM) |

AUDIO jacks

| | |
|----|---|
| IN | Pin jack -10 dBu Impedance: Minimum 47 k Ω (kilo ohms), unbalanced Maximum input level: +16 dBu (= approx. 5 Vrms) 60i system +14 dBu (= approx. 4 Vrms) 50i system |
|----|---|

OUT

| |
|--|
| Pin jack Impedance: Maximum 1 k Ω (kilo ohms) Output level: 47 k Ω (kilo ohms) loading, unbalanced -10 dBu (= full bit -20 dB) 60i system -10 dBu (= full bit -18 dB) 50i system |
|--|

VIDEO jacks

| | |
|--------|--|
| IN/OUT | Pin jack, unbalanced 1.0 Vp-p (75 Ω (ohms), sync negative) Sync signal: 0.286 Vp-p (60i/NTSC) 0.3 Vp-p (50i/PAL) Burst signal: 0.286 Vp-p (60i/NTSC) 0.3 Vp-p (50i/PAL) |
|--------|--|

S VIDEO jacks

| | |
|--------|---|
| IN/OUT | Mini DIN 4-pin, unbalanced Luminance signal: 1.0 Vp-p (75 Ω (ohms), sync negative) Sync signal: 0.286 Vp-p (60i/NTSC) 0.3 Vp-p (50i/PAL) Chrominance signal: 0.286 Vp-p (60i/NTSC) (burst, 75 Ω (ohms)) 0.3 Vp-p (50i/PAL) (burst, 75 Ω (ohms)) |
|--------|---|



Specifications

COMPONENT OUT jacks

- OUT** Pin jack
- Output at 480i NTSC
- With [BETACAM] selected in [480i LEVEL] of the [IN/OUT REC] menu
- Y: 1.0 Vp-p
(with 0.286 Vp-p sync negative, output impedance 75 Ω (ohms), unbalanced)
- Pb/Cb/B-Y, Pr/Cr/R-Y: 0.7 Vp-p
(output impedance 75 Ω (ohms), unbalanced) (75% color bars with 7.5 IRE setup)
- With [SMPTE] selected in [480i LEVEL] of the [IN/OUT REC] menu
- Y: 1.0 Vp-p
(with 0.3 Vp-p sync negative, output impedance 75 Ω (ohms), unbalanced)
- Pb/Cb/B-Y, Pr/Cr/R-Y: 0.7 Vp-p
(output impedance 75 Ω (ohms), unbalanced) (100% color bars with no setup)
- Output with other settings
- Y: 1.0 Vp-p
(output impedance 75 Ω (ohms), unbalanced)
- Pb/Cb/B-Y, Pr/Cr/R-Y: 0.7 Vp-p
(output impedance 75 Ω (ohms), unbalanced)
(100% color bars with no setup)
- 480i/480p:
Y: with 0.3 Vp-p sync negative
- 1080i/720p:
Y/Pb/Pr: with 0.6 Vp-p 3-level sync

- Power requirements
DC 8.4 V (DC IN jack)
- Power consumption (during playback)
6 W
- Operating temperature
5 °C to 40 °C (41 °F to 104 °F)
- Storage temperature
-20 °C to +60 °C
(-4 °F to +140 °F)
- Dimensions
Approx. 180 × 72.8 × 270.1 mm
(7 1/8 × 2 7/8 × 10 3/4 inches)
(w/h/d, including projecting parts and controls)

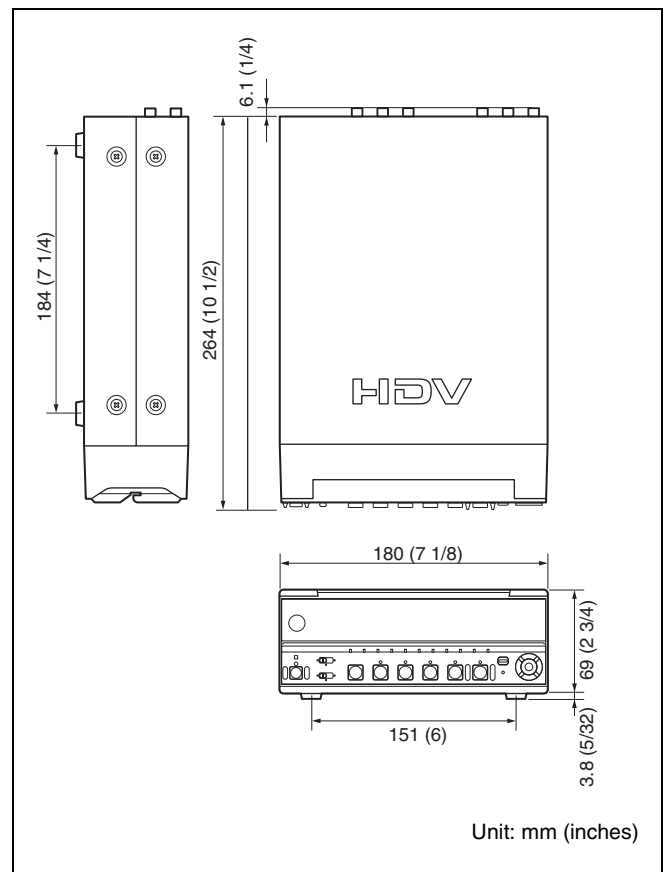

i HDV/DV jack

- i.LINK (IEEE 1394,
6-pin connector S100)

Remote control

- LANC Stereo mini-mini jack (ø 2.5)
- CONTROL S IN Stereo mini jack (ø 3.5)

General

- Peak inrush current
Hot switching inrush current,
measured in accordance with
European standard
EN55103-1: 4.0 A (230 V)

Mass Approx. 2.3 kg (5 lb. 1 oz.)

Supplied accessories

- Remote Commander (1)
- AC Adaptor (1)
- Power cord (1)
- Rack (1)
- Cleaning cassette (1)
- CD-ROM "Manuals for Digital HD
Videocassette Recorder" (1)
- Operating Instructions (2)

AC Adaptor AC-L100

Power requirements

AC 100 V - 240 V, 50 Hz/60 Hz

Current consumption

0.35 A - 0.18 A

Power consumption

18 W

Output voltage

DC OUT: 8.4 V *

Operating temperature

0 °C to 40 °C (32 °F to 104 °F)

Storage temperature

-20 °C to +60 °C (-4 °F to +140 °F)

* See the label on the AC Adaptor for other specifications.

Design and specifications are subject to change without notice.



S

| | |
|-----------------------------|----|
| S VIDEO jack..... | 12 |
| Scheduled maintenance | 70 |
| Search | 34 |
| SEARCH SELECT button | 16 |
| Self-diagnosis | 65 |
| SHUTTLE MAX button..... | 16 |
| Specifications | 75 |
| STOP button..... | 9 |

T

| | |
|-----------------------|----|
| TC/UB SET menu | 56 |
| Troubleshooting | 59 |

U

| | |
|-----------------------|----|
| Unlock mode | 24 |
| Usable cassette | 20 |

V

| | |
|--------------------|----|
| VIDEO jack..... | 12 |
| VTR SET menu | 55 |

W

| | |
|---------------|----|
| Warning | 65 |
|---------------|----|

X

| | |
|----------------|----|
| x.v.Color..... | 23 |
|----------------|----|



Submenu Index

Numerics

| | |
|-------------------|----|
| 480i LEVEL | 53 |
| 60i/50i SEL | 58 |

A

| | |
|--------------------|----|
| AC ON MODE..... | 58 |
| AUDIO AGC..... | 54 |
| AUDIO LOCK..... | 54 |
| AUDIO MIX | 54 |
| AUDIO MODE | 54 |
| AUDIO REC LV | 54 |
| AUTO INDEX | 55 |
| AUTO REPEAT..... | 55 |

B

| | |
|-----------------|----|
| BARS TYPE | 52 |
|-----------------|----|

C

| | |
|-----------------|----|
| CLOCK SET | 58 |
| COLOR BAR | 52 |
| COMMANDER | 57 |

D

| | |
|--------------------|----|
| DATA CODE..... | 53 |
| DATE DISPLAY | 53 |
| DV BARS..... | 52 |

E

| | |
|----------------|----|
| EE/PB SEL..... | 52 |
|----------------|----|

F

| | |
|--------------------|----|
| FF/REW SPEED | 55 |
| FROM REC P..... | 56 |
| FROM STILL..... | 56 |

H

| | |
|--------------------|----|
| HDV/DV IN TC | 56 |
| HDV/DV SEL | 50 |
| HOURS METER..... | 58 |

I

| | |
|------------------|----|
| i.LINK SET | 51 |
| INITIALIZE | 58 |

J

| | |
|----------------|----|
| JOG AUDIO..... | 55 |
|----------------|----|

L

| | |
|-------------------|----|
| LANGUAGE | 57 |
| LETTER SIZE | 53 |

P

| | |
|--------------|----|
| PB CNR | 58 |
| PB YNR | 57 |

R

| | |
|----------------|----|
| REC MODE | 50 |
| REMAINING..... | 53 |

S

| | |
|------------------|----|
| STILL PICT | 55 |
| STILL TIME..... | 55 |

T

| | |
|--------------------|----|
| TC FORMAT | 57 |
| TC RESET | 57 |
| TIME DISPLAY | 53 |

V

| | |
|----------------|----|
| VIDEO OUT..... | 51 |
|----------------|----|



<http://www.sony.net/>



Printed on 70% or more recycled paper using
VOC (Volatile Organic Compound)-free
vegetable oil based ink.

Printed in Japan

GB



3878917110

Other ManualsLib Projects



www.manualslib.com



www.manualslib.de



www.manualslib.es



www.manualslib.fr



www.manualslib.nl



www.manualslib.mx



www.manualslib.tech 30+ Languages